

CBSE Class 10 Science  
Important Questions  
Chapter 12  
Electricity

---

**1 Marks Questions**

1. Which two circuit components are connected in parallel in the following circuit diagram?

- (a)  $R_1$  and  $R_2$  only
- (b)  $R_1, R_2$  only
- (c)  $R_2$  and  $V$  only
- (d)  $R_1$  and  $V$  only

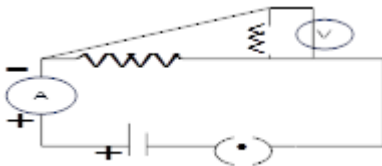

Ans.  $R_1$  and  $R_2$  only

---

2. A metallic conductor has loosely bound electrons called free electrons. The metallic conductor is

- (a) negatively charged
- (b) positively charged
- (c) neutral
- (d) Either positively charged or negatively charged

Ans. (c) neutral

---

3. Which of the following expressions does not represent the electric power in the circuit?

- (a)  $VI$
- (b)  $I^2 / R$
- (c)  $V^2 / R$
- (d)  $I^2R$

Ans. (b)  $I^2 / R$

---

4. Resistivity of a metallic wire depends on

- (a) its length
- (b) its shape
- (c) its thickness
- (d) nature of material

Ans. (d) nature of material

---

5. If the current  $I$  through a resistor is increased by 100% the increased in power dissipation will be (assume temperature remain unchanged)

- (a) 100%
- (b) 200%
- (c) 300%
- (d) 400%

Ans. (c) 300%

---

6. For the circuit arrangement shown below, a student would observe.

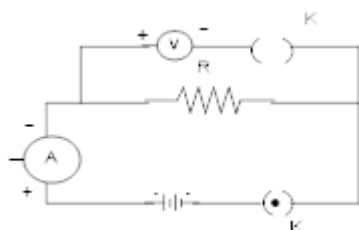

- (a) Some reading in both ammeter and voltmeter.

(b) No reading in either the ammeter or the voltmeter.

(c) Some reading in the ammeter but no reading in the voltmeter.

(d) Some reading in the voltmeter but no reading in the ammeter.

Ans. (c) Some reading in the ammeter but no reading in the voltmeter.

---

7. A wire of resistance  $R$  is cut into five equal pieces. These pieces are connected in parallel and the equivalent resistances of the combination are  $R'$ . Then the

ratio  $\frac{R}{R'}$  is

(a)  $\frac{1}{5}$

(b) 5

(c)  $\frac{1}{25}$

(d) 25

Ans. (d) 25

---

8. The resistance of the conductor is  $R$ . If its length is doubled, then its new resistance will be

(a)  $R$

(b)  $2R$

(c)  $4R$

(d)  $8R$

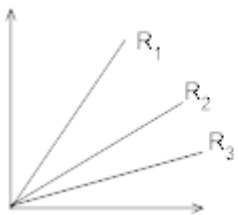

(a)  $R_3 > R_2 > R_1$

(b)  $R_2 > R_3 > R_1$

(c)  $R_1 > R_2 > R_3$

(d)  $R_1 = R_2 = R_3$

Ans. (c)  $4R$

9. A student carries out an experiment and plots the V-I graph of three samples of nichrome wire with resistances  $R_1$ ,  $R_2$  and  $R_3$  respectively as shown in the figure. Which of the following is true?

Ans.  $\left( R \propto \frac{1}{\text{slope of V-I graph}} \right)$

---

10. The nature of the graph between potential difference and the electric current flowing through a conductor is

- (a) parabolic
- (b) circle
- (c) straight line
- (d) hyperbolic

Ans. (c) straight line

---

11. An electric heater is salted at 1500w. How much heat is produced per hour?

- (i) 5400 J
- (ii) 54000 J
- (iii)  $5.4 \times 10^5$  J
- (iv)  $5.4 \times 10^6$  J

Ans. (iv)  $5.4 \times 10^6$  J

---

12. A student says that the resistance of two wires of same length and same area of cross section is same. This statement is correct if

- (a) Both wires are of different materials
- (b) Both wires are made of same material and are at different temperature.
- (c) Both wires are made of same material and are at same temperature.
- (d) Both wires are made of different materials and are at the same temperature.

Ans. (c) Both wires are made of same material and are at same temperature.

---

13. In an experiment ohm's law a student obtained a graph as shown in the diagram. The value of resistance of the resistor is

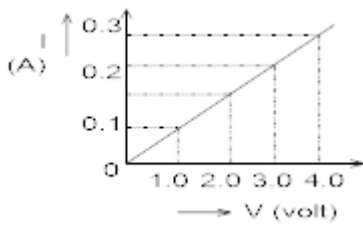

- (a)  $0.1 \Omega$
- (b)  $1.0 \Omega$
- (c)  $10 \Omega$
- (d)  $100 \Omega$

Ans.  $100\Omega \left( R = \frac{1}{\text{slope}} = \frac{V}{I} = \frac{1.0}{0.1} = 10\Omega \right)$

14. Work done to move 1 coulomb charge from one point to another point on a charged conductor having potential 10volt is

- (a) 1 Joule
- (b) 10 Joule
- (c) zero
- (d) 100 Joule

Ans. (c) zero

15. Three resistors are shown in the figure. The resistance of the combination is

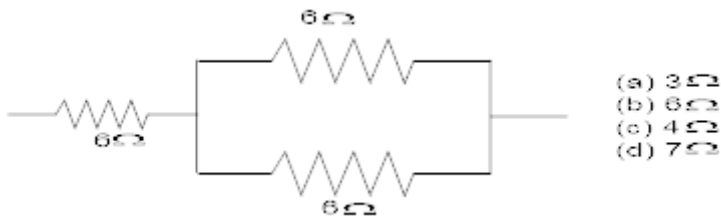

- (a)  $3 \Omega$
- (b)  $6 \Omega$
- (c)  $4 \Omega$
- (d)  $7 \Omega$

Ans.  $100\Omega$

16. Name a device that helps to maintain a potential difference between across a conductor.

Ans. Battery.

17. What determines the rate at which energy is delivered by a current?

Ans. Electric power determines the rate at which energy is delivered by a current.

18. A piece of wire of resistance  $R$  is cut into five equal parts. These parts are then connected in parallel. If the equivalent resistance of this combination is  $R'$ , then the ratio  $R/R'$  is:

- (a)  $1/25$
- (b)  $1/5$
- (c)  $5$
- (d)  $25$

Ans. (d)  $25$

---

19. Which of the following terms does not represent electrical power in a circuit?

- (a)  $I^2R$
- (b)  $IR^2$
- (c)  $VI$
- (d)  $V^2/R$

Ans. (b)  $IR^2$

---

20. An electric bulb is rated  $220\text{ V}$  and  $100\text{ W}$ . When it is operated on  $110\text{ V}$ , the power

consumed will be:

- (a)  $100\text{ W}$
- (b)  $75\text{ W}$
- (c)  $50\text{ W}$
- (d)  $25\text{ W}$

Ans. (d)  $25\text{ W}$

---

21. Two conducting wires of the same material and of equal lengths and equal diameters are first connected in series and then parallel in a circuit across the same potential difference.

The ratio of heat produced in series and parallel combination would be:

- (a)  $1:2$

(b) 2:1

(c) 1:4

(d) 4:1

Ans. (c) 1:4

---

**22. A wire of resistance R is bent in form of a closed circle, what is the resistance across a diameter of the circle?**

Ans.  $1/R' = 1/(R/2) + 1/(R/2)$   $R' = R/4$

---

**23. A charge of 6 C is moved between two points P and Q having, potential 10V and 5V respectively. Find the amount of work done.**

Ans.  $W = q(V_2 - V_1) = 6(10 - 5) = 30$  joule

---

**24. Name the physical quantity whose SI unit is JC**

Ans. Potential

---

**25. Why are copper wires used as connecting wires?**

Ans. The electrical resistivity of copper is low.

---

**26. A wire of resistivity  $\rho$  is stretched to double its length. What is its new resistivity?**

Ans. It remains same because resistivity depends on nature of material.

---

**27. What is the resistance of connecting wire?**

Ans. The resistance of a connecting wire, which is made of good conductor, is negligible.

---

**28. What is the resistance of an ammeter?**

Ans. The resistance of an ammeter is very small and for an ideal ammeter, its value is zero.

---

## 29. What is the resistance of a Voltmeter?

**Ans.** The internal resistance of an ideal voltmeter is infinity and the internal resistance of an ideal ammeter is zero.

## 2 Marks Questions

### 1. How does use of fuse wire protect electrical appliances?

**Ans.** When large amount of current flows through the circuit, temperature of the wire increases and fuse wire gets melted. This in term prevent the flow of current in the other circuits of the house and thus saved electrical appliances.

---

### 2. Calculate the resistance of an electric bulb which allows a 10A current when connected to a 220V power source?

**Ans.**  $I=10A$ ,  $V=220V$

$$R = \frac{V}{I} = \frac{220}{10} = 22 \text{ ohm}$$

---

### 3. (i) Identify the V-I graphs for ohmic and non-ohmic materials.

(ii) Give one example of each.

**Ans. (i)(a)** Ohmic material

**(b)** Non-ohmic material

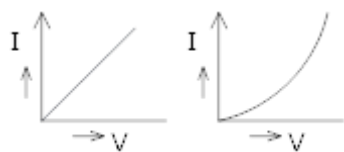

**(ii)** Example of ohmic material - Copper, Nichrome etc.

Example of Non-ohmic material –Diode, Transistor etc.

---

### 4. What do the following symbols represent in a circuit?

Write the name and one function of each?

(a)

(b)

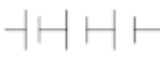

**Ans. (i)**  It represents a battery which maintains a potential difference across the circuit element for the flow of current in the circuit.

**(ii)**  It is an ammeter which measures the current flowing in the circuit.

---

### 5. Define the term “volt”?

**Ans.** The potential difference between two points A and B is said to be one volt if 1 joule of work is done to move 1 coulomb of charge from one point to another point in an electric field.

---

### 6. Why does the connecting rod of an electric heater not glow while the heating element does?

**Ans.** The connecting cord of an electric heater does not glow because its resistance is less as compared to the heating element. Hence more heat is produced in the heating element as compared to the connecting cord and it glows.

---

### 7. n resistors each of resistance R are first connected in series and then in parallel. What is the ratio of the total effective resistance of the circuit in series combination and parallel combination?

**Ans.** In series combination  $R_s = nR$

For parallel  $R_p = \frac{R}{n}$

$$\frac{R_s}{R_p} = \frac{nR}{\frac{R}{n}} = n^2$$

---

### 8. Draw a schematic diagram of a circuit consisting of 3V battery, 5 ohm, 3 $\Omega$ and 1 $\Omega$ resistor, an ammeter and a plug key, all connected in series.

**Ans.**

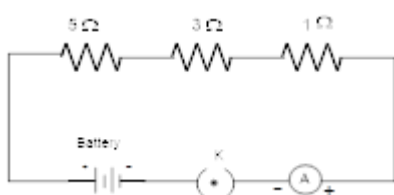

**9. A copper wire has diameter 0.5mm and Resistivity of  $1.6 \times 10^{-8} \Omega m$  what be the length of this wire to make its resistance  $10 \Omega$ ? How much does the resistance change if diameter is doubled?**

**Ans.**  $D = 0.5 \text{ mm} = 0.5 \times 10^{-3} \text{ m}$

$\rho = 1.62 \times 10^{-8} \Omega m$

$R = 10 \Omega$

$$R = \frac{\rho l}{A} = \frac{\rho l}{\pi r^2} = \frac{\rho l}{\pi \left(\frac{D}{2}\right)^2} = \frac{4\rho l}{\pi D^2}$$

$$\Rightarrow l = \frac{\pi R D^2}{4\rho}$$

$$l = \frac{3.14 \times 10 \times (5 \times 10^{-4})^2}{4 \times 1.62 \times 10^{-8}} = 121.14 \text{ m}$$

**Length of the wire,  $l = 121.14 \text{ m}$**

$$R^1 = \frac{4\rho l}{\pi (D^1)^2} = \frac{4\rho l}{\pi 2D^2} = \frac{1}{4} \left( \frac{4\rho l}{\pi D^2} \right) = \frac{R}{4}$$

$$R^1 = \frac{1}{4} R$$

---

**10. Alloys are used in electrical heating devices rather than pure metals. Give reason.**

**Ans.** Alloys are used in electricity heating devices rather than pure metals because Resistivity of an alloy is more and hence more heat is produced in any alloy. Moreover, alloy does not burn (or oxidize easily at higher temperature).

---

**11. On what factor does the resistance of a conductor depend?**

**Ans.** Resistance depends on the following factors

(1)  $R \propto l$  (length of the conductor)

(2)  $R \propto l/A$  (area of cross - section)

(3)  $R \propto t$  (temperature)

(4)  $R$  depends on nature of material.

---

**12. Calculate the number of electron consisting one coulomb of charge?**

**Ans.**  $q \times 1e$

$x =$  no. of electrons

Since  $= n e$

$$x = q/e = \frac{1}{1.6 \times 10^{-19}}$$

$$x = 6.25 \times 10^{18} \text{ electrons}$$

---

**13. What does an electric circuit mean?**

**Ans.** An electric circuit is a continuous and closed path of an electric current. If the electric circuit complete, current can flow through the circuit.

---

**14. Define the unit of current.**

**Ans.** SI unit of electric current is Ampere. Current is said to be 1 ampere, if 1 coulomb charge flows per second across a cross-section of conductor.

---

**15. Calculate the number of electrons constituting one coulomb of charge.**

**Ans.** Charge on one electron  $= 1.6 \times 10^{-19}$  coulomb.

No of electron in one coulomb of charge  $= 1/1.6 \times 10^{-19}$

$$= 6.25 \times 10^{18}$$

---

**16. What is meant by saying that the potential difference between two points is 1 v?**

**Ans.** The potential difference between two points is said to be 1 volt, if 1 joule of work is to be done for moving charge of 1 coulomb from one point to another.

---

**17. Ammeter burns out when connected in parallel. Give reasons.**

**Ans.** Ammeter consists of a wire of low resistance when connected in parallel, a large amount of current passes through it hence gets burnt i.e. short circuited.

---

**18. Judge the equivalent resistance when the following are connected in parallel:**

**(a) 1  $\Omega$  and  $10^6 \Omega$**

**(b) 1  $\Omega$ ,  $10^3 \Omega$  and  $10^6 \Omega$**

**Ans.** When the resistances are joined in parallel, the resultant resistance in parallel arrangement is given by:

$$1/R = 1/R_1 + 1/R_2 + 1/R_3 \text{ ----}$$

**(a)**  $1/R = 1/1 + 1/10^6 = 1 + 10^{-6}$

$$R = 1\Omega$$

**(b)**  $1/R = 1/1 + 1/10^3 + 1/10^6 = 1 + 10^{-3} + 10^{-6}$

$$R = 1\Omega$$

---

**19. An electric iron of resistance 20 takes a current of 5 A. Calculate the heat developed in 30 s.**

**Ans.** Resistance of electric iron (R) = 20 $\Omega$ , current (I) = 5 A and time = 30 s.

$$\text{Heat generated } (H) = I^2 R t = 5^2 \times 20 \times 30 = 15000 \text{ j.}$$

---

**20. Compute the heat generated while transferring 96000 coulomb of charge in one hour**

**through a potential difference of 50 V.**

**Ans.** Charge transferred (Q) = 96000 C, time = 1 hour =  $60 \times 60 = 3600 \text{ s}$  and potential difference (V) = 50 V.

$$\text{Heat generated } (H) = V I t = V \cdot Q = 50 \times 96000 = 4800000 \text{ j} = 4.8 \times 10^6 \text{ j} .$$

---

**21. An electric motor takes 5 A from a 220 V line. Determine the power of the motor and energy consumed in 2 h.**

**Ans.** It is given that current drawn by electric motor (I) = 5 A. the line voltage V = 220 V time (t) = 2

h. Power of motor (P) =  $P = VI = 220 \times 5 = 1100 \text{ W}$  and the energy

consumed  $(E) = Pt = 1100 \text{ W} \times 2 \text{ h}$

= 2200 Wh or 2.2 kWh.

---

**22. How is a voltmeter connected in the circuit to measure the potential difference between two points?**

**Ans.** A voltmeter is always connected in parallel to resistance across the point between which the potential difference is to be measured.

---

**23. When a 12 v battery is connected across an unknown resistor, there is a current of 2.5 mA in the circuit. Find the value of the resistance of the resistor.**

**Ans.** Voltage of battery =  $V = 12 \text{ V}$ , Current ( $I$ ) =  $2.5 \text{ mA} = 2.5 \times 10^{-3} \text{ A}$

Resistance ( $R$ ) =  $V/I = 12\text{V} / 2.5 \times 10^{-3} \text{ A} = 4800 \Omega$ .

---

**24. Several electric bulbs designed to be used on a 220 V electric supply line, are rated 10 W. How many lamps can be connected in parallel with each other across the two wires of 220V line if the maximum allowable current is 5 A?**

**Ans.** Each bulb is rated as 10 W, 220 V, It draws a current ( $I$ ) =  $P/V = 10\text{W}/220 \text{ V} = 1/22 \text{ A}$ .

As the maximum allowable current is 5A and all lamps are connected in parallel, hence maximum number of bulbs joined in parallel with each other =  $5 \times 22 = 110$ .

---

**25. Two lamps, one rated 100 W at 220 V, and the other 60 W at 220 V are connected in parallel to electric mains supply. What current is drawn from the line if the supply voltage is 220 V?**

**Ans.** Current drawn by 1<sup>st</sup> lamp rated 100 W at 220 V =  $P/V = 100/220 = 5/11 \text{ A}$ .

Current drawn by 2<sup>nd</sup> lamp rated 60 W at 220 V =  $60/220 = 3/11 \text{ A}$ .

In parallel arrangement the total current =  $I_1 + I_2 = 3/11 + 5/11 = 8/11 = 0.73 \text{ A}$ .

---

**26. Which uses more energy, a 250 W TV set in 1 hour, or a 1200 W toaster in 10 minutes?**

**Ans.** Energy used by a TV set of power 250 W in 1 hour =  $P \times t = 250 \text{ Wh}$ .

Energy used by toaster of power 1200 W in 10 minute (10/60 h)

=  $P \times t = 1200 \text{ W} \times 10/60 \text{ h} = 200 \text{ Wh}$ .

---

27. An electric heater of resistance 8 draws 15 A from the service mains for 2 hours. Calculate the rate at which heat is developed in the heater.

Ans. Resistance of electric heater (R) = 8Ω, current (I) = 15 A.

Rate at which heat developed in the heater =  $I^2 R t / t = 15 \times 15 \times 8 = 1800 \text{ W}$ .

28. In the given figure what is the ratio of current in A

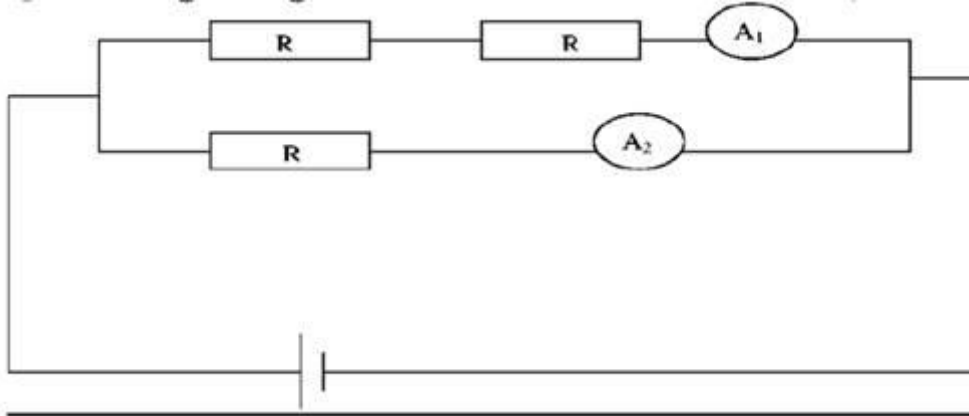

Ans.  $V=IR$

$V=\text{const.}$

$$I \propto 1/R \quad I_1 / I_2 = R / 2R \quad I_1 / I_2 = 1 / 2$$

29. Two wires of equal cross sectional area, one of copper and other of manganing have same resistance. Which one will be longer?

Ans.

$$R = \rho L / A \quad (R, A = \text{const}, L = 1 / \rho)$$

$\rho_{\text{manganin}} > \rho_{\text{copper}}$

$L_{\text{copper}} > L_{\text{manganin}}$

30. A Rectangular block of iron has dimensions  $L \times L \times b$ . What is the resistance of the block measured between the two square ends? Given  $\rho$  resistivity.

Ans.  $R = \rho b / L^2$

31. Three equal resistances are connected in series then in parallel. What will be the ratio of their Resistances?

Ans.  $R_{\text{series}} = 3R$

$$R_{\text{parallel}} = R/3$$

$$R_{\text{series}} / R_{\text{parallel}} = 3R / (R/3) = 9$$

---

**32. Justify for any pair of resistance the equivalent resistance equivalent resistance in parallel.**

Ans. Since,  $V/I$

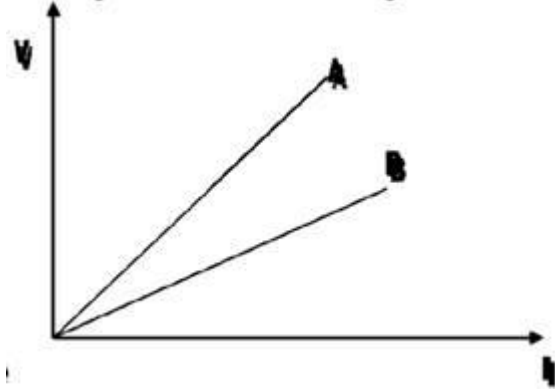

$$R_A > R_B$$

A=Series, B=Parallel

---

**33. How many bulbs of 81 should be joined in parallel to draw a current of 2A from a battery of 4 V?**

Ans.  $R = V/I = 4/2 = 2 \Omega$ , let 'n' battery of bulbs.

$$1/R = 1/R_1 + 1/R_2 + \dots + 1/R_n = n/8$$

$$\frac{1}{2} = n/8, n = 4$$

---

**34. Two cubes A and B are of the same material. The side of B is thrice as that of A. Find the ratio  $R_A/R_B$ .**

$$\text{Ans. } R_A = \rho L/A \quad R_B = \rho 3L/9A$$

$$R_A : R_B = 3 : 1$$

---

**35.  $3 \times 10^{11}$  electrons are flowing through the filament of bulb for two minutes. Find owing through the circuit. Charge on one electron =  $1.6 \times 10^{-19} \text{ C}$ .**

$$\text{Ans. } q = ne = 3 \times 10^{11} \times 1.6 \times 10^{-19} = 4.8 \times 10^{-8} \text{ C}$$

$$I = q/t = \frac{4.8 \times 10^8}{(2 \times 60)} = 4 \times 10^7 \text{ A}$$

---

**36. A nichrome wire of resistivity 100Ωm and copper wire of resistivity 1.62M ohm-m of same length and same area of cross section are connected in series, current is passed through them, why does the nichrome wire gets heated first?**

**Ans.**  $Q = I^2 R t$

$$Q = I^2 \left\{ \frac{\rho L}{A} \right\} t$$

Nichrome wire has higher resistivity than copper wire Therefore, it is heated first.

---

**37. What is represented by joule/coulomb?**

**Ans.** It represents potential difference.

---

**38. A charge of 2C moves between two plates, maintained at a p.d of 1V. What is the energy acquired by the charge?**

**Ans.**  $W = QV = 2 \times 1 = 2 \text{ J}$

The resistance of a voltmeter is very high and for an ideal voltmeter, its value is infinity.

---

**39. Which has more resistance: 100W bulb or 60W bulb?**

**Ans.** As  $R \propto 1/P$ . Thus, the resistance of 60W bulb is more.

---

**40. What happens to the current in a circuit if its resistance is doubled?**

**Ans.** If  $R$  is doubled, the current is reduced to half of its previous value.

---

**41. What happens to the resistance of a circuit if the current through it is doubled?**

**Ans.** The resistance of the circuit does not depend on the current through it.

---

**42. How does the resistance of a wire depend upon its radius?**



Ans. As  $R \propto 1/A$ ,  $R \propto 1/r$  i.e.  $R \propto 1/r$

---

**43. Two wires are of the same length, same radius, but one of them is of copper and the other is of iron. Which will have more resistance.**

Ans. As  $R = \rho l/A$ , but  $A$  and  $l$  are same it depends only on resistivity and it is more for iron so iron has more resistance.

---

**44. Two wires of same material and same length have radii  $r$  and  $r$  Compare their resistances.**

Ans. If  $R$  and  $l$  are resistances, then  $R = r$  because  $\rho$  and  $l$  are same.

### 3 Marks Questions

**1. Two metallic wires A and B are connected in series wire A has length  $l$  and radius  $r$ , while wire B has length  $2l$  and radius  $2r$ . Find the ratio of total resistance of series combination and the resistance of wire A, if both the wires are of same material?**

Ans. Resistance of wire A  $(R_1) = \frac{\rho l}{A} = \frac{\rho l}{\pi r^2}$

Resistance of wire B  $(R_2) = \frac{\rho l'}{A'} = \frac{\rho 2l}{\pi(2r^2)} = \frac{\rho 2l}{4\pi r^2}$

Total resistance in series

$$R = R_1 + R_2$$

$$R = \frac{\rho l}{\pi r^2} + \frac{\rho 2l}{4\pi r^2}$$

$$R = \frac{\rho l}{\pi r^2} \left(1 + \frac{1}{2}\right) = \frac{3\rho l}{2\pi r^2}$$

Ratio of the total resistance in series to the resistance of A

$$\frac{R}{R_1} = \frac{\rho l}{\pi r^2} \div \frac{3\rho l}{2\pi r^2}$$

$$\Rightarrow \frac{R}{R_1} = \frac{\rho l}{\pi r^2} \times \frac{2\pi r^2}{3\rho l}$$

$$\frac{R}{R_1} = \frac{2}{3}$$

---

**2. Should the heating element of an electric iron be made of iron, silver or nichrome wire? Justify giving three reasons?**

**Ans.** Heating element of an electric iron is made up of nichrome wire because of the following reasons.

(1) Resistivity is high because of which more heat is produced due to the passage of current.

(2) Melting point is high.

(3) It does not oxidize (or burn) easily at high temperature.

---

**3. (a) Define electric resistance of a conductor?**

**(b)** A wire of length  $L$  and resistance  $R$  is stretched so that its length is double and the area of cross section is halved. How will its

(i) resistance change

(ii) resistivity change?

**Ans. (a)** It is defined as the opposition offered by the resistor to the flow of current

i.e  $R = V/I$  its S.I. unit is ohm ( $\Omega$ )

**(b) (i)**  $R = \frac{\rho l}{A}$  (1)

New length  $L' = 2L$  and  $A' = \frac{A}{2}$  (since volume remains same)

$$\therefore R_1 = \frac{\rho L'}{A'}$$

$$R_1 = \frac{\rho 2L}{\frac{A}{2}} \quad (2)$$

$$R_1 = 4 \left( \frac{\rho L}{A} \right)$$

$$R_1 = 4R$$

ie resistance of a wire becomes 4 times its original resistance.

**(ii)** since Resistivity does not depend on the dimensions of a wire. So it remains unchanged.

---

**4. Two resistor of resistance R and 2R are connected in parallel in an electric circuit. Calculate the ratio of the electric power consumed by R and 2R?**

**Ans.** power  $(P_1) = \frac{V^2}{R}$  (consumption by R)

$P_2 = \frac{V^2}{2R}$  (consumption by 2R)

Ratio  $\frac{P_1}{P_2} = \frac{V^2}{R} \times \frac{2R}{V^2} = 2:1$

---

**5. The length of different metallic wires but of same area of cross section and made of the same material are given below**

Wire	Length
A	1 m
B	1.5 m
C	2.0 m

**(i) Out of these two wires which wire has higher resistance.**

**(ii) Which wire has higher electrical Resistivity? Justify your answer.**

**Ans. (i)** Since  $R \propto l$  (length of the conductor)

Since length of wire C is more than A and B therefore wire C has higher resistance.

**(ii)** Electrical Resistivity of a wire depends on the nature of the material and not on dimensions of a wire hence Resistivity of all wires is same as material of all the wires is same.

---

**6. Two resistors of resistances R and 2R are connected in series is an electrical circuit? Calculate the ratio of the electric power consumed by R and 2R?**

**Ans.** Electric power consumed by

R is  $(P_1) = I^2 R$

$2R (P_2) = I^2 (2R)$

$\frac{P_1}{P_2} = \frac{I^2 R}{I^2 2R}$

$P_1 : P_2 = 1:2$

---

7. Two conducting wires of the same material and of equal lengths and equal diameters are first connected in series and then in parallel in an electric circuit. the ratio of heat produced in series and parallel combinations would be

- (a) 1:2
- (b) 2:1
- (c) 1:4
- (d) 4:1

**Ans. (c)** Let resistance of each wire is R

In series, resistance is therefore = 2R

Heat produced,  $H_1 = \frac{V^2}{2R} (t)$

In parallel total resistance =  $\frac{R}{2}$

Heat produced  $H_2 = \left( \frac{V^2}{\frac{R}{2}} \right) t = \frac{2V^2}{R} t$

$$H_2 = 4H_1$$

$$\Rightarrow \frac{H_1}{H_2} = 1:4$$

## 8. Calculate

(i) effective resistance

(ii) current

(iii) Potential difference across  $10\Omega$  resistor of a circuit shown in the figure.

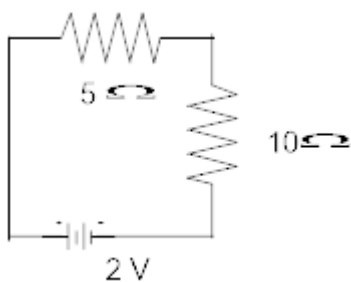

**Ans. (i)**  $R = R_1 + R_2 = 5 + 10 = 15\Omega$

$$(ii) I = \frac{V}{R} = \frac{2}{15} = 0.133A$$

(iii) Potential difference across  $10\Omega$

$$V = IR = \frac{2}{15} \times 10 = 1.33 \text{ volt}$$

---

9. A piece of wire of resistance  $20\Omega$  is drawn out so that its length is increased to twice its original length calculate the resistance of the wire in the new situation?

Ans. Since  $R = \frac{\rho l}{A}$  (1)

Since length of a wire is increased, its area of cross-section decreases, as volume of the wire remains constant.

$$l' = 2l$$

$$Al = A'l'$$

$$Al = A'2l$$

$$A' = \frac{A}{2}$$

$$\text{Then new } R' = \frac{\rho l'}{A'} = \frac{\rho(2l)}{\frac{A}{2}}$$

$$R' = \frac{4\rho l}{A} \quad (2)$$

Dividing (2) by (1)

$$\frac{R'}{R} = \frac{4}{1}$$

$$R' = 4R = 4(20\Omega)$$

$$R' = 80\Omega$$

---

10. A battery made of 5 cells each of 2 V and have internal resistance  $0.1\Omega, 0.2\Omega, 0.3\Omega, 0.4\Omega,$  and  $0.5\Omega$  is connected across  $10\Omega$  resistance. Draw circuit diagram and calculate the current flowing through  $10\Omega$  resistance?

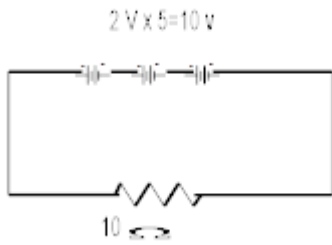

**Ans.** Internal resistance  $1.5 \Omega$  ( $0.1+0.2+0.3+0.4+0.5$ )

Total resistance =  $(1.5+10) \Omega = 11.5 \Omega$

$I = V/R = 10/11.5$

$I = 0.869 \text{ A}$

**11. In the circuit diagram given here Calculate-**

**(a) The total effective resistance**

**(b) The total current**

**(c) The current through each resistor.**

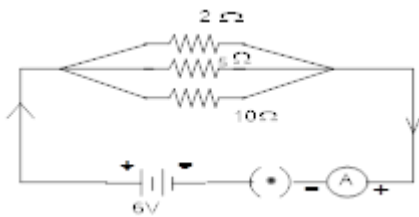

**Ans. (a)** since resistances are in parallel

$$\frac{1}{R} = \frac{1}{R_1} + \frac{1}{R_2} + \frac{1}{R_3}$$

$$\frac{1}{R} = \frac{1}{2} + \frac{1}{5} + \frac{1}{10} = \frac{8}{10}$$

$$R = \frac{10}{8} \Omega$$

**(b) Total current**  $I = \frac{V}{R} = \frac{6\text{v}}{10/8\Omega} = 4.8\text{A}$

**(c)** If  $I_1, I_2$  And  $I_3$  be the current through  $2\Omega, 5\Omega$  and  $10\Omega$  Respectively

$$\therefore I_1 = \frac{V}{R_1} = \frac{6}{2} = 3\text{A}$$

$$I_2 = \frac{V}{R_2} = \frac{6}{5} = 1.2\text{A}$$

$$I_3 = \frac{V}{R_3} = \frac{6}{10} = 0.6A$$

---

**12. You have two circuits (i) a 6V battery is series with  $1\Omega$  and  $2\Omega$  resistor**

**(ii) a 4V battery in parallel with  $12\Omega$  and  $2\Omega$  resistor. Compare the power used in  $2\Omega$  resistor in each case.**

**Ans. (i)**  $V=6V$   $R_1 = 1\Omega$   $R_2 = 2\Omega$

Total Resistor  $R=R_1 + R_2 = 1+2 = 3\Omega$

$$I = \frac{V}{R} = \frac{6}{3} = 2A$$

$$\therefore \text{power}(P_1) = I^2 R = (2)^2 \times 2 = 8W$$

**(ii)**  $V=4V$ ,  $R_1 = 12\Omega$ ,  $R_2 = 2\Omega$

$$P_2 = \frac{V^2}{R} = \frac{4 \times 4}{2} = 8W$$

$$\text{Ratio } \frac{P_1}{P_2} = \frac{8}{8} = 1:1$$

---

**13. How much energy is given to each coulomb of charge passing through a 6 volt battery?**

**Ans.** Potential difference (V) = 6 V

Charge (Q) = 1 C

Energy = total work done (W) = Q x V = 1x6 = 6 joule.

---

**14. On what factor does the resistance of a conductor depend?**

**Ans.** The resistance of a conductor depends on

i. length of conductor (l)

ii. Area of cross-section (A)

iii. Temperature

iv. Nature of material used to make conductor.

---

**15. Will current flow more easily through a thick wire or a thin wire of the same material, when connected to the same source? Why?**

**Ans.** The current flows more easily through a thick wire as compared to thin wire of the same material, when connected to the same source. It is due to the reason that resistance increases with decrease in thickness.

---

**16. Let the resistance of an electric component remains constant while the potential difference across the two ends of the component decreases to half of its former value. What change will occur in the current through it?**

**Ans.** It is given that resistance  $R$  of the electrical component remains constant but the potential difference across the ends of the component decreases to half of its value.

Hence, as per Ohm's law, new current also decreases to half of its original value.

---

**17. Why are coils of electric toasters and electric irons made of an alloy rather than a pure metal?**

**Ans.** Coils of electric toasters and electric irons are made of an alloy due to the following reasons:

- i. Resistivity of an alloy is generally higher than that of pure metal.
  - ii. At high temperature, an alloy does not oxidize readily. Hence, coil of an alloy has longer life.
- 

**18. Draw a schematic diagram of a circuit consisting of a battery of three cells of 2 V, each, a 5  $\Omega$  resistor, 8  $\Omega$  resistors and a 12  $\Omega$  and a plug key, all connected in series.**

**Ans.** The schematic diagram of circuit is as follows:

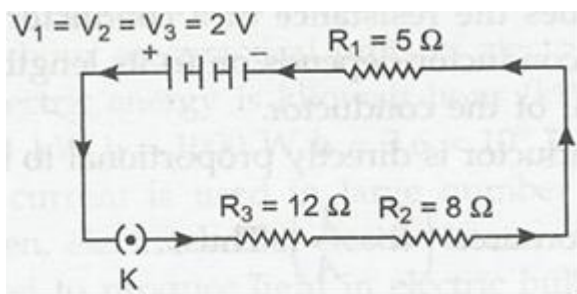

**19. An electric lamp of 100  $\Omega$ , a toaster of resistance 50  $\Omega$  and a water filter of resistance 500  $\Omega$  are connected in parallel to a 220 V source. What is the resistance of an electric iron connected to the same source that takes as much current as all three appliances, and what is the current through it?**



**Ans.** Here, voltage (V) = 220 V

$$R_1 = 100\Omega, R_2 = 50\Omega \text{ and } R_3 = 500\Omega$$

$$1/R = 1/R_1 + 1/R_2 + 1/R_3 \text{ ----}$$

$$1/R = 1/100 + 1/50 + 1/500 = 16/500$$

$$R = 500/16 = 31.25 \Omega$$

The resistance of electric iron, which draws as much current as all three appliances take together =  $R = 31.25 \Omega$ . Current passing through electric iron (I) =  $V/R = 220/31.25 = 7.04 \text{ A}$ .

---

**20. What is (a) the highest, (b) the lowest total resistance that can be secured by combination of four resistance of 4  $\Omega$ , 8  $\Omega$ , 12  $\Omega$  and 24  $\Omega$ ?**

**Ans. (a)** To obtain highest resistance, all the four resistances must be connected in series

arrangement. In that case resultant  $R = R_1 + R_2 + R_3$

$$= 4 + 8 + 12 = 24 \Omega$$

**(b)** To obtain lowest resistance, all the four resistance must be connected in parallel arrangement.  $1/R = 1/R_1 + 1/R_2 + 1/R_3$

$$= 1/4 + 1/8 + 1/12 + 1/24 = 12/24 \Omega$$

---

**21. Why does the cord of an electric heater not glow while the heating element does?**

**Ans.** Cord of heater and electric heater are joined in series and carry same current when joined to voltage source. As resistance of cord is extremely small as compared to that of heater element. hence, heat produced is extremely small in cord but much larger in heater element. So, the heating element begins to glow but cord does not glow.

---

**22. A copper wire has diameter 0.5 mm and resistivity of  $1.6 \times 10^{-8} \text{ m}$ . what will be the length of this wire to make its resistance 10? How much does the resistance change if the diameter is doubled?**

**Ans.** Diameter of wire (d) = 0.5 mm, resistivity ( $\rho$ )  $1.6 \times 10^{-8} \Omega \text{m}$ , resistance (R) = 10  $\Omega$ .

$$R = \rho L/A$$

$$L = \pi D^2 R / 4\rho$$

$$= 22 \times (5 \times 10^{-4})^2 / 7 \times 4 \times 1.6 \times 10^{-8}$$

$$= 122.5 \text{ m}$$

If the diameter is doubled for given length of given material resistance is inversely proportional to the cross-section area of wire.

---

**23. A battery of 9 V is connected in series with resistance of 0.2  $\Omega$ , 0.3  $\Omega$ , 0.4  $\Omega$ , 0.5  $\Omega$  and 12  $\Omega$**

**respectively. How much current would flow through the 12 resistor?**

**Ans.** Potential difference (V) = 9 V.

$$\text{Total resistance } (R) = R_1 + R_2 + R_3 + R_4 + R_5$$

$$= 0.2 + 0.3 + 0.5 + 0.5 + 12 = 13.4 \Omega$$

$$\text{Current in the circuit } (I) = V/R = 9 \text{ V} / 13.4 \Omega = 0.67 \text{ A.}$$

In series circuit same current flows through all the resistance, hence current of 0.67 A will flow through 12  $\Omega$  resistor.

---

**24. How many 176  $\Omega$  resistors (in parallel) are required to carry 5 A on a 220 V line?**

**Ans.** Let a resistor of 176  $\Omega$  are joined in parallel. Then their combined resistance (R)

$$1/R = 1/176 + 1/176 \dots \text{ times} = n/176 \text{ or } R = 176/n \Omega$$

It is given that V= 220 V and I = 5 A

$$R = V/I \text{ or } 176/n = 220/5 = 44 \Omega$$

$$n = 176/44 = 4, 4 \text{ resistors should be joined in parallel.}$$

---

**25. Show how you would connect three resistors, each of resistance 6  $\Omega$  so that the combination has resistance of (i) 9  $\Omega$  (ii) 4  $\Omega$ .**

**Ans.** It is given here that  $R_1 = R_2 = 6 \Omega$ .

(i) To get net resistance of 9  $\Omega$  we should join three resistors as below:



(ii) To get 4  $\Omega$  net resistance we should join three resistors as below:

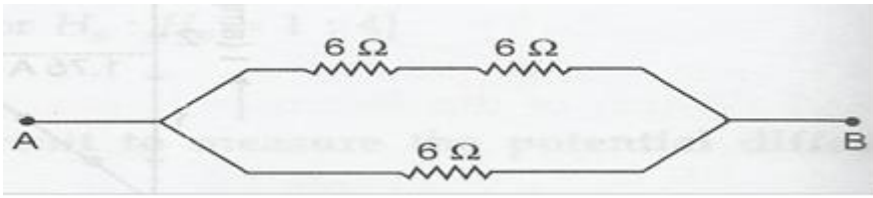

**26. A hot plate of an electric oven connected to a 220 V line has two resistance coils A and B. Each of 24 Ω resistances, which may be used separately, in series or in parallel. What are the currents in the three cases?**

**Ans.** It is given that potential difference (V) = 220 V.

Resistance of coil (A) = Resistance of coil (B) = 24 Ω

(i) When either coil is used separately, the circuit (I) =  $V/R = 220 \text{ V} / 24 \Omega$   
= 9.2 A.

(ii) When two coils are used in series total resistance (R)

$$= R_1 + R_2 = 24 + 24 = 48 \Omega$$

Current flowing (I) =  $V/R = 220 \text{ V} / 48 \Omega = 4.6 \text{ A}$ .

(ii) When two coils are joined in parallel. Total resistance (R) =  $1/24 + 1/24$

$$= 2/24, R = 12 \Omega.$$

Current (I) =  $V/R = 220 \text{ V} / 12 \Omega = 18.3 \text{ A}$ .

**27. Compare the power used in the 2 Ω resistor in each of the following circuits:**

(i) a 6 volt battery in series with 1 Ω and 2 Ω resistors and,

(ii) a 4 V battery in parallel with 12Ω and 2Ω resistors.

**Ans. (i)** When a 2Ω resistor is joined to a 6 V battery in series with 1Ω and 2Ω resistors.  
Total

$$\text{resistance (R)} = 2 + 1 + 2 = 5\Omega.$$

$$\text{Current (I)} = 6\text{V}/5\Omega = 1.2 \text{ A}$$

$$\text{Power used in 2 A resistor} = I^2R = 2.88 \text{ W}$$

(ii) When 2Ω resistor is joined to a 4 V battery in parallel with 12Ω resistor and 2Ω resistors, the current flowing in 2Ω =  $4 \text{ V} / 2\Omega = 2 \text{ A}$ .

$$\text{Power used in 2Ω resistor} = I^2R = 8 \text{ W}$$

Ratio =  $2.88/8 = 0.36: 1$ .

28. In the given figure what is ratio of ammeter reading when J is connected to A and then to B

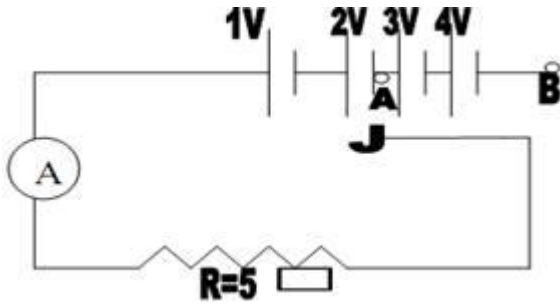

Ans. when J is connected to A

$$I = V/R = 3/5 \text{A} = 0.6 \text{A}$$

When J is connected to B

$$V = 1 + 2 + 3 + 4 = 10 \text{V}$$

$$I = 10/5 = 2 \text{A}$$

29. Given a resistor each of resistors R. How will you combine them to get the (i) maximum and (ii) minimum effective resistance? What is the ratio of the maximum to minimum resistance?

Ans. for maximum resistance  $R_s = nr$  (Equivalent of series combination) for minimum resistance  $R_p = nr$  (Equivalent of parallel combination)  $R_s / R_p = n^2$

30. A wire of length L and resistance R is stretched so that its length its doubled. How will its (a) Resistance change (b) Resistively change?

Ans. Resistance of a wire is related to its length, area of cross-section and resistivity

as 
$$R = \frac{\rho l}{A}$$

Hence, if the length is doubled and area is halved, then we have

$$\frac{R_2}{R_1} = \frac{\frac{\rho l_2}{A_2}}{\frac{\rho l_1}{A_1}} = \frac{l_2 A_1}{l_1 A_2} = \frac{2l_1 A_1}{l_1 \frac{1}{2} A_1} = 4$$

$$\therefore R_2 = 4R_1$$

Hence, resistance of the wire becomes four times the original value.

Resistivity of the wire is the property of the material from which wire is made.

Hence, by changing the dimensions of the wire, its resistivity does not change.

---

**31. Two students perform the experiments on series and parallel combinations of two given resistors ( $R_1$  and  $R_2$ ) and plot the following V-I graphs.**

**Ans.** Both are correct because  $AV/AI = \text{resistance}(R)$  and  $A1/AI = I/R$  Series means high resistance and parallel means low resistance. Which of the graphs is (are) correctly labelled in terms of the words 'series' and 'parallel' Justify your answer.

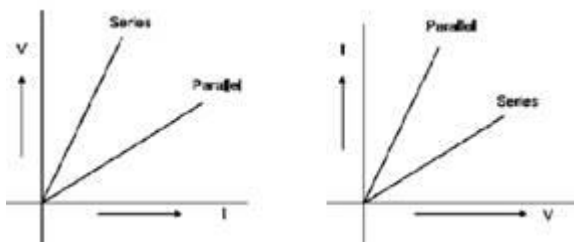

**32. A household uses the following electric appliances**

**(i) Refrigerator of rating 4 for ten hours each thy.**

**(ii) Two electric fans of rating 8 each for twelve hours each day.**

**(iii) Six electric tubes of rating 18 W each for 6 hours each day.**

**Calculate the electricity bill of the household for the month of June if the cost per unit of electric energy is Rs. 3.00.**

**Ans.** Month of June has 30 days.

i. Refrigerator of 400 W is run 2 hours each day.

Total hours it is run in 30 days =  $2 \times 30 = 60$  h

Energy consumed in kWh is =  $400 \times 60/1000 = 24$  kWh

ii. Two electric fans of 80 W are run 12 hours each day.

Total hours they are run in 30 days =  $12 \times 30 = 360$  h

Energy consumed in kWh is =  $2 \times 80 \times 360/1000 = 57.6$  kWh

iii. Six electric tubes each of 18 W are run 6 hours daily.

Total hours it is run in 30 days =  $6 \times 30 = 180$  h

Energy consumed in kWh is =  $6 \times 18 \times 180/1000 = 19.44$  kWh

Net energy consumed in the month of June is =  $24 + 57.6 + 19.44 = 101.04$  kWh

Thus, the electric bill is =  $3 \times 101.04 = \text{Rs } 303.12$

## 5 Marks Questions

1. Two wires A and B are of equal length, different cross sectional areas and made of same metal.

(a)(i) Name the property which is same for both the wires,

(ii) Name the property which is different for both the wires.

(b) If the resistance of wire A is four times the resistance of wire B, calculate

(i) the ratio of the cross sectional areas of the wires and

(ii) The ratio of the radii of the wire.

**Ans. (a) (i)** Resistivity – since the Resistivity is a property of a substance hence it remains the same for both the wires.

**(ii)** Resistances – As both the wires are of different cross sectional areas, so both wires are

considered as different objects.

(b) (i) Since  $R = \frac{\rho L}{A}$

For wire A  $(R_1) = \frac{\rho l}{A_1}$

For wire B  $(R_2) = \frac{\rho l}{A_2} \Rightarrow \frac{R_2}{R_1} = \frac{A_1}{A_2}$

Since  $R_1 = 4R_2 \Rightarrow \frac{A_1}{A_2} = 1:4 \Rightarrow \frac{A_1}{A_2} = \frac{\pi r_1^2}{\pi r_2^2} = \left(\frac{r_1}{r_2}\right)^2$

(ii)  $\Rightarrow \left(\frac{r_1}{r_2}\right)^2 = \frac{1}{4}$

$r_1:r_2 = 1:2$

---

2. (a) State ohm's law?

(b) The value of (I) current following through a conductor for the corresponding values of (V) potential difference are given below

I (Ampere)	0.5	1.0	1.5	2.5	3
V (Volt)	1	2	3	4.5	5

**Plot a graph between V and I and also calculate resistance.**

**Ans. (a)** At constant temperature the electric current flowing in a conductor is directly proportional to the potential difference across the end of a conductor provided the temperature and other physical conditions of the conductor remain the same.

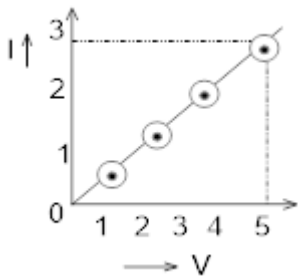

**(b)** Along x-axis  $IV=1$  cm

Y-axis  $IA=1$  cm

$$R = \frac{1}{\text{Slope of curve } OA} = \frac{OB}{AB}$$

$$R = \frac{5}{3} = 1.67\Omega$$

**3. (a) Define electrical energy with S.I. unit?**

**(b) A house hold uses the following electric appliance;**

**(i) Refrigerator of rating 400w for ten hour each day.**

**(ii) Two electric fans of rating 80w each for twelve hours each day.**

**(iii) Six electric tubes of rating 18w each for 6hours each day.**

**Calculate the electricity bill of the household for the month of June if the cost per unit of electric energy is Rs. 3.00.**

**Ans. (a)** The work done by a source of electricity to maintain current in a circuit is known as electrical energy. Its S.I. unit is joule.

**(b) (i)** Electricity consumed by refrigerator in one day

$$= \text{power} \times \text{time}$$

$$= 400 \text{ W} \times 10 \text{ h}$$

$$= 4000 \text{ Wh} = 4 \text{ kwh}$$

(ii) Electricity consumed by 2 electric fans in 1 day

$$= \text{power} \times \text{Time}$$

$$= 2 \times 80 \text{ W} \times 12 \text{ h}$$

$$= 1920 \text{ Wh} = 1.92 \text{ kWh}$$

(iii) Electricity consumed by 6 electric tubes in 1 day

$$= 6 \times 18 \text{ W} \times 6 \text{ h}$$

$$= 648 \text{ Wh} = 0.648 \text{ kWh}$$

Total energy consumed in one day

$$= 4 + 1.92 + 0.648 = 6.568 \text{ kWh}$$

Total energy consumed in one month

$$= 6.568 \times 30 = 197.04 \text{ kWh}$$

Cost of 1 unit (kWh) = Rs 3.00

Cost of 197.04 kWh =  $197.04 \times 3$

Electricity bill = Rs 591.12

**4. Redraw the circuit of question 1, putting in an ammeter to measure the current through the resistors and a voltmeter to measure the potential difference across the 12 Ω resistors. What would be the reading in the ammeter and voltmeter?**

**Ans.**

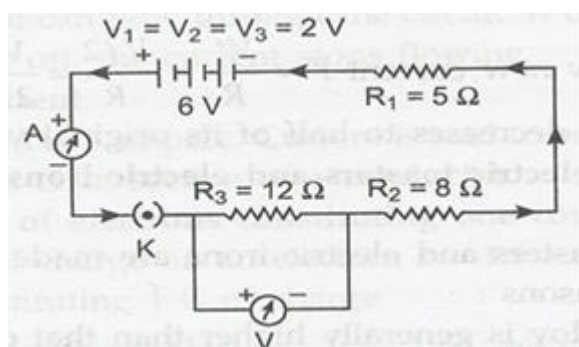

Here ammeter A has been joined in series of circuit and voltmeter V is joined in parallel to 12 ohms resistor.

Total voltage of battery  $V = 3 \times 2 = 6 \text{ V}$ .

Total resistance  $R = R_1 + R_2 + R_3 = 5 \Omega + 8 \Omega + 12 \Omega = 25 \Omega$

Ammeter reading (current)  $= I = V/R = 6/25 = 0.24 \text{ A}$ .



Voltmeter reading =  $IR = 0.24 \times 12 = 2.88 \text{ V}$ .

---

**5. What are the advantages of connecting electrical devices in parallel with the battery instead of connecting them in series?**

**Ans.** Advantage of connecting electrical devices in parallel with the battery are as follows:

(i) Voltage across each connecting electrical device is same and device take current as per its

resistance.

(ii) Separate on/off switches can be applied across each device.

(iii) Total resistance in parallel circuit decreases, hence, a great current may be drawn from cell.

(iv) If one electrical device is damaged, then other devices continue to work properly.

---

**6. How can three resistors of resistance  $2\Omega$ ,  $3\Omega$  and  $6\Omega$  be connected to give a total resistance of (a)  $4\Omega$  (b)  $9\Omega$ ?**

**Ans. (a)** If we connect resistance of  $3\Omega$  and  $6\Omega$  in parallel and then resistance of  $2\Omega$  is connected in series of the combination, then total resistance of combination is  $4\Omega$ .

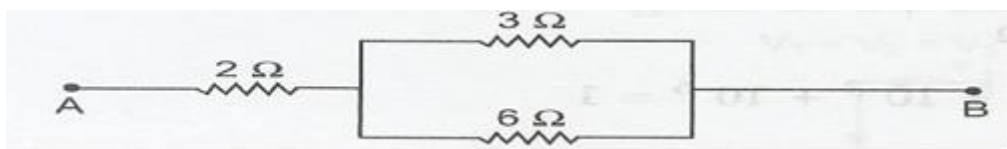

(b) If all the three resistance are joined in parallel the resultant resistance will be  $3\Omega$ .

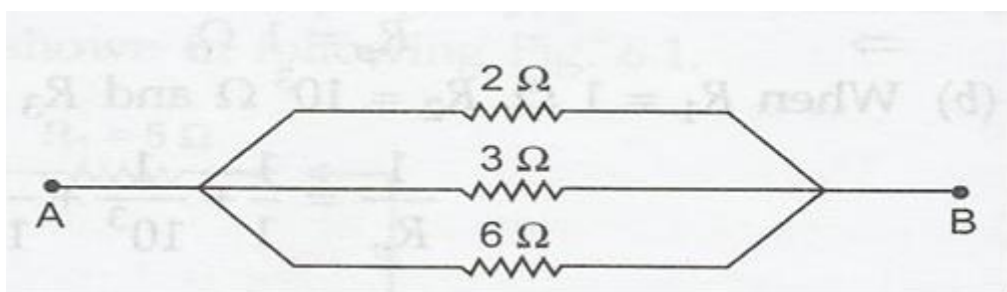

**7. The value of current  $I$  flowing in a given resistor for the corresponding values of potential**

**difference  $V$  across the resistor are given below:**

I (amperes)	0.5	1.0	2.0	3.0	4.0
V (volts)	1.6	3.4	6.7	10.2	13.2

**Plot a graph between V and I and calculate the resistance of that resistor.**

**Ans.** From the given data the I-V graph is a straight line as shown below:

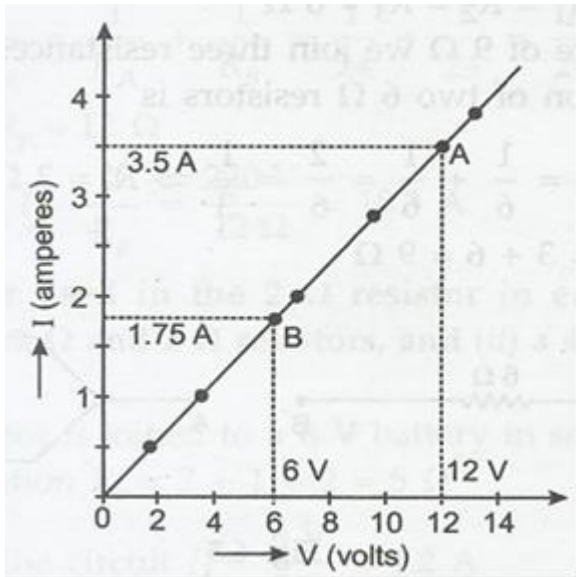

$$\text{Resistance of resistor (R)} = \frac{V_A - V_B}{I_A - I_B} = \frac{12 \text{ V} - 6 \text{ V}}{3.6 \text{ A} - 1.8 \text{ A}}$$

$$= \frac{6 \text{ V}}{1.8 \text{ A}} = 3.3 \Omega$$

**8. Explain the following:**

- Why is the tungsten used almost exclusively for filament of electric lamps?
- Why are the conductors of electric heating devices, such as bread-toasters and electric irons, made of an alloy rather than a pure metal?
- Why is the series arrangement not used for domestic circuits?
- How does the resistance of wire vary with its area of cross-section?
- Why are copper and aluminum wires usually employed for electric transmission?

**Ans. (a)** For filament of electric lamp we require a strong metal with high melting point.

Tungsten is used exclusively for filament of electric lamps because its melting point is extremely

high.

(b) Conductors of electric heating devices are made of an alloy rather than a pure metal due to high resistivity than pure metal and high melting point to avoid getting oxidized at high temperature.

(c) Series arrangement is not used for domestic circuits as current to all appliances remain same in spite of different resistance and every appliance can not be switched on/ off independently.

(d) Resistance of a wire is inversely proportional to its cross-section area.

(e) Copper and aluminum wires are usually employed for electricity transmission because they are good conductor with low resistivity. They are ductile also to be drawn into thin wires.

### (1 Mark Questions)

1. In the given figure what is the ratio of current in  $A_1$ , and  $A_2$

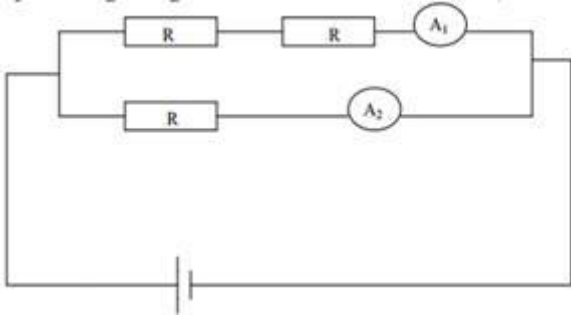

Ans- $V=IR$

$I \propto 1/R$

$V=\text{const.}$

$I_1/I_2 = R/2R$

$I_1/I_2 = 1/2$

2. A wire of resistance  $R$  is bent in form of a closed circle, what is the resistance across a diameter of the circle?

Ans- $1/R' = 1/(R/2) + 1/(R/2)$   $R'=R/4$ .

3. A charge of 6 C is moved between two points P and Q having, potential 10V and 5V respectively. Find the amount of work done.

Ans- $W=q(V_2-V_1) = 6(10-5) = 30$  joule

4. Name the physical quantity whose SI unit is  $JC^{-1}$ .

Ans-Potential

---

### (2 Marks Questions)

1. Two wires of equal cross sectional area, one of copper and other of manganin have same resistance. Which one will be longer?

Ans- $R=\rho L/A$  ( $R,A=\text{const.}$   $L=1/\rho$ )

$\rho_{\text{manganin}} > \rho_{\text{copper}}$

$L_{\text{Copper}} > L_{\text{manganin}}$

2. A Rectangular block of iron has dimensions  $L \times L \times b$ . What is the resistance of the block measured between the two square ends? Given  $\rho =$  resistivity.

Ans-  $R = \rho b/L^2$

3. Three equal resistances are connected in series then in parallel. What will be the ratio of their Resistances?

Ans-  $R_{\text{series}} = 3R$ .

$R_{\text{parallel}} = R/3$

$R_{\text{series}}/R_{\text{parallel}} = 3R/(R/3) = 9$

4. Justify for any pair of resistance the equivalent resistance in series is greater equivalent resistance in parallel.

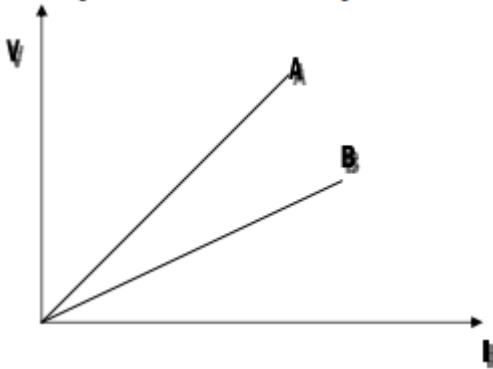

Ans- Since,  $R = V/I$

$R_A > R_B$

A=Series, B=Parallel

5. How many bulbs of  $8\Omega$  should be joined in parallel to draw a current of 2A from a battery of 4 V?

Ans-  $R = V/I = 4/2 = 2\Omega$ , let 'n' be the no of bulbs.

$1/R = 1/R_1 + 1/R_2 + \dots + 1/R_n = n/8$

$1/2 = n/8, n = 4$ .

6. Two cubes A and B are of the same material. The side of B is thrice as that of A. Find

Ans-  $R_A = \rho L/A, R_B = \rho 3L/9A$

$= R_A: R_B = 3:1$

7.  $3 \times 10^{11}$  electrons are flowing through the filament of bulb for two minutes. Find the current flowing through the circuit. Charge on one electron =  $1.6 \times 10^{-19} \text{ C}$ .

Ans-  $q = ne = 3 \times 10^{11} \times 1.6 \times 10^{-19} = 4.8 \times 10^{-8} \text{ C}$

$I = q/t = 4.8 \times 10^{-8} / (2 \times 60) = 4 \times 10^{-7} \text{ A}$

8. A nichrome wire of resistivity  $100 \times 10^{-6} \text{ ohm-m}$  and copper wire of resistivity  $1.62 \times 10^{-8} \text{ ohm-m}$  of same length and same area of cross section are connected in series, current is passed through them, why does the nichrome wire gets heated first?

Ans.  $Q = I^2 R t$

$Q = I^2 \{ \rho L/A \} t$

Nichrome wire has higher resistivity than copper wire. Therefore, it is heated first

**(3 Marks Question)**

1. In the given figure what is ratio of ammeter reading when J is connected to A and then to B

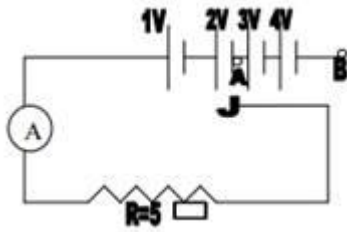

**Ans.** when J is connected to A

$$I = V/R = 3/5 \text{A} = 0.6 \text{A}$$

When J is connected to B

$$V = 1 + 2 + 3 + 4 = 10 \text{V}$$

$$I = 10/5 = 2 \text{A}$$

## HOTS Questions and Answers

1. **What is represented by joule/coulomb?**

**Ans.** It represents potential difference.

2. **A charge of 2C moves between two plates, maintained at a p.d of 4V. What is the energy acquired by the charge?**

**Ans.**  $W = QV = 2 \times 4 = 8 \text{J}$

3. **Why are copper wires used as connecting wires?**

**Ans.** The electrical resistivity of copper is low.

4. **A wire of resistivity  $\rho$  is stretched to double its length. What is its new resistivity?**

**Ans.** It remains same because resistivity depends on nature of material.

5. **What is the resistance of connecting wire?**

**Ans.** The resistance of a connecting wire, which is made of good conductor, is negligible.

6. **What is the resistance of an ammeter?**

**Ans.** The resistance of an ammeter is very small and for an ideal ammeter, its value is zero.

7. **What is the resistance of a Voltmeter?**

**Ans.** The resistance of a voltmeter is very high and for an ideal voltmeter, its value is infinity.

8. **Which has more resistance: 100W bulb or 60W bulb?**

**Ans.** As  $R \propto 1/P$ . Thus, the resistance of 60W bulb is more.

9. **How will you join three resistances, each of 2 $\Omega$  so that the effective resistance is 3 $\Omega$ ?**

**Ans.** A parallel combination of two resistances (which will be 1 $\Omega$ ) joined in series with the third resistance (3 $\Omega$ )

10. **What happens to the current in a circuit if its resistance is doubled?**

**Ans.** As  $I \propto 1/R$ , the current is reduced to half of its previous value.

11. **What happens to the resistance of a circuit if the current through it is doubled?**

**Ans.** The resistance of the circuit does not depend on the current through it.

12. **How does the resistance of a wire depend upon its radius?**

**Ans.** As  $R \propto 1/A$ ,  $R \propto 1/\pi r^2$  i.e.  $R \propto 1/r^2$ .

13. **Two wires are of the same length, same radius, but one of them is of copper and the other is of iron. Which will have more resistance?**

**Ans.** As  $R = \rho l/A$ , but  $A$  and  $l$  are same it depends only on resistivity and it is more for iron so iron has more resistance.

14. Two wires of same material and same length have radii  $r_1$  and  $r_2$ . Compare their resistances.

**Ans.** If  $R_1$  and  $R_2$  are resistances, then  $R_1/R_2 = r_2^2/r_1^2$  because  $\rho$  and  $l$  are same.

15. Given a resistors each of resistors  $R$ . How will you combine them to get the maximum and minimum effective resistance? What is the ratio of the maximum to minimum resistance?

**Ans.** for maximum resistance  $R_s = nr$  (Equivalent of series combination) for minimum resistance  $R_p = r/n$  (Equivalent of parallel combination)  $R_s/R_p = n^2$

16. A wire of length  $L$  and resistance  $R$  is stretched so that its length its doubled. How will its  
 a. Resistance change  
 b. Resistivity change?

**Ans.**

- a. If the original length of the wire is  $l$  and its cross-sectional area is  $A$ , then  $R = \rho l/A$ . When length becomes  $2l$ , cross-sectional area reduces to  $A/2$  because volume does not change. The new resistance  $= \rho (2l)/(A/2) = 4\rho l/A = 4R$   
 b. Resistivity does not change.

17. Two students perform the experiments on series and parallel combinations of two given resistors  $R_1$  and  $R_2$  and plot the following V-I graphs.

Which of the graphs is (are) correctly labelled in terms of the words 'series' and parallel' Justify your answer.

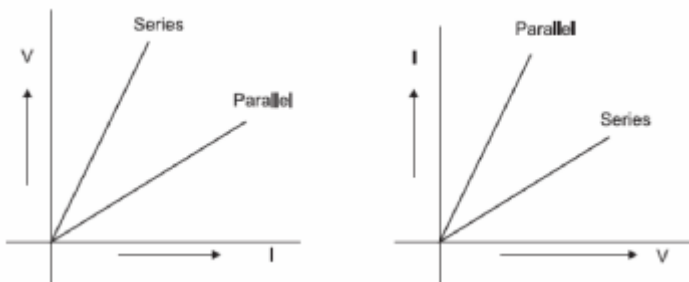

**Ans.** Both are correct because  $\Delta V/\Delta I = \text{resistance}(R)$  and  $\Delta I/\Delta V = 1/R$  Series means high resistance and parallel means low resistance.

18. A household uses the following electric appliances:

- i. Refrigerator of rating 400W for ten hours each day.
  - ii. Two electric fans of rating 80W each for twelve hours each day.
  - iii. Six electric tubes of rating 18W each for 6 hours each day.
- Calculate the electricity bill of the household for the month of June if the cost per unit of electric energy is Rs. 3.00.

**Ans.** Electrical energy consumed per day  $= 400 \times 10 + 2 \times 80 \times 12 + 6 \times 18 \times 6$   
 $= 4000 + 1920 + 648 = 6568 \text{ kWh} = 6.568 \text{ kWh}$

Electrical energy consumed in 30 days  $= 6.568 \times 30$   
 $= 197 \text{ kWh (units)}$

Electric Bill  $= 197 \times 3$   
 $= \text{Rs } 591.$

19. Ammeter bums out when connected in parallel. Give reasons.

**Ans.** Ammeter consists of a wire of low resistance when connected in

parallel, a large amount of current passes through it hence gets burnt i.e. short circuited