

**CBSE Class 10 Science
Important Questions
Chapter 10
Light Reflection and Refraction**

1 Marks Questions

1. An object is kept at a distance more than twice the focal length (F) from a concave mirror. The distance the image formed will be

- (a) less than F
- (b) equal to F
- (c) between F and 2 F
- (d) More than 2 F

Ans. (c) between F and 2 F

2. The speed of light, in a given medium is $\frac{2}{3}$ rd of its speed in vacuum. The absolute refractive index of the medium equals to

- (a) $\frac{9}{4}$
- (b) $\frac{4}{9}$
- (c) $\frac{3}{2}$
- (d) $\frac{2}{3}$

Ans. (c) between F and 2 F

3. A ray passing through the centre of curvature of a concave mirror is inclined at an angle α to its principal axis. The angle of reflection for this ray equals

- (a) 0°
- (b) $\left(\frac{\alpha}{2}\right)^\circ$
- (c) α°
- (d) 90°

Ans. (a) 0°

4. Beams of light are incident through the holes C and D respectively as shown in the figure. Which of the following could be inside the box?

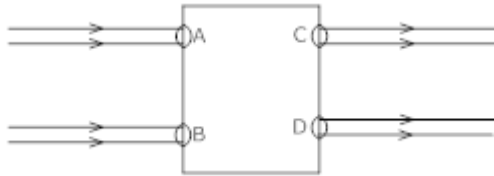

- (a) A rectangular glass slab
- (b) Convex lens
- (c) Concave lens
- (d) Prism

Ans. (a) A rectangular glass slab

5. What are the values of (i) Angle of incidence and (ii) Angle of reflection for normal incidence on a plane surface?

Ans. (0°) $\angle i = \angle r$

6. The power of a lens is -4.0 D. what is the nature of the lens?

- (a) Plane
- (b) Concave
- (c) Convex
- (d) Plano convex

Ans. (b) Concave

7. Where should an object be placed in front of a convex lens to get real image of the size of the object?

- (a) At focus
- (b) At 2F
- (c) At Infinity
- (d) Between optical centre and focus.

Ans. (b) At 2F

8. In torches, search lights and head lights of vehicles the bulb is placed

- (a) Between pole and focus
- (b) Very near to the focus
- (c) Between focus and centre of curvature
- (d) At centre of curvature

Ans. (b) Very near to the focus

9. Figure shows a ray of light as it travels from medium A to B. Refractive index of medium B with respect to A is

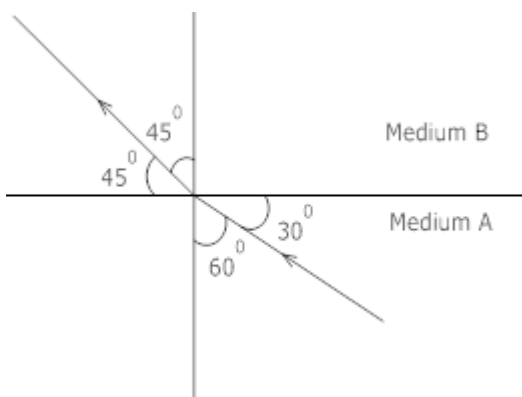

- (a) $\frac{\sqrt{3}}{\sqrt{2}}$
- (b) $\frac{1}{\sqrt{2}}$

(c) $\frac{\sqrt{2}}{\sqrt{3}}$

(d) $\frac{\sqrt{2}}{\sqrt{2}}$

Ans. (a) $\frac{\sqrt{3}}{\sqrt{2}}$

10. When a ray of light goes from one medium to another, there is

- (a) Always a change in its speed as well as direction
- (b) No change in speed and direction
- (c) A change in speed but no change in direction
- (d) A change in direction but constant speed.

Ans. (a) Always a change in its speed as well as direction

11. Name the mirror that can give an erect and enlarged image of an object?

Ans. Concave mirror

12. The rays, parallel to the principal axis, of a spherical mirror, actually meet at a point 20 cm distant from its pole. Identify the mirror and give its focal length.

Ans. Concave mirror and $f = 20$ cm

13. Name the kind of surfaces that

- (i) Reflect
- (ii) Refract most of the light falling on them.

Ans. (i) Concave mirror

(ii) Convex lens

14. Which type of mirror is usually used as a rear-view mirror in motor cars?

Ans. Convex mirror

15. Define one dioptre of power of a lens?

Ans. Power of a lens is one dioptre if focal length of a lens is 1 m

16. Define 1 dioptre of power of lens.

Ans. One dioptre of is defined as the power of lens having a focal length of 1 m.

17. Find the power of a concave lens of focal length 2 m.

Ans. Focal length of concave lens = - 2 m.

$$P = 1/f = 1/(-2 \text{ m})$$

$$= -0.5 \text{ D}$$

18. Which one of the following materials cannot be used to make a lens?

(a) Water

(b) Glass

(c) Plastic

(d) Clay

Ans. (d) Clay

19. The image formed by a concave mirror is observed to be virtual, erect and larger than the object. Where should be the position of the object?

(a) Between the principal focus and the centre of curvature.

(b) At the centre of curvature

(c) Beyond the centre of curvature

(d) Between the pole of the mirror and its principal focus.

Ans. (d) Between the pole of the mirror and its principal focus.

20. Where should an object be placed in front of convex lens to get a real image of the size of the object?

- (a) At the principal focus of the lens.**
- (b) At twice the focal length**
- (c) At infinity**
- (d) Between the optical centre of the lens and its principal focus.**

Ans. (b) At twice the focal length

21. A spherical mirror and thin spherical lens have each of focal length of -15 cm. the mirror and lens are likely to be

- (a) Both concave**
- (b) Both convex**
- (c) The mirror is concave and the lens is convex**
- (d) The mirror is convex and lens is concave.**

Ans. (a) Both concave

22. No matter how far you stand from a mirror, your image appears erect. The mirror is likely to be

- (a) Plane**
- (b) Concave**
- (c) Convex**
- (d) Either concave or convex.**

Ans. (d) Either concave or convex.

23. Which of the following lens would you prefer to use while reading small letters found in a dictionary?

- (a) A convex lens of focal length 50 cm**
- (b) A concave lens of focal length 50 cm**
- (c) A convex lens of focal length 5 cm**

(d) A concave lens of focal length 5 cm

Ans. (c) A convex lens of focal length 5 cm

24. A ray AFB is incident on a spherical mirror whose centre of curvature is 2 F. In which direction will it reflect?

Ans. It will reflect towards the object side parallel to principal axis.

25. A ray of light is incident at angle of 35° to a plane surface. What will the angle of reflection?

Ans. 55°

26. How does image changes when the face is slowly moved away from inner face of a shining spoon?

Ans. As the face is moved away than after a particular time image becomes inverted.

27. Due to which property of light, sharp shadow of an object is obtained?

Ans. straight line property of the light.

28. Where is the image formed in a convex mirror, when the object is anywhere in front of it?

Ans. Between pole and focus, behind the convex mirror.

29. A person uses concave minor for shaving, where should he position his face in front of it?

Ans. Between pole and principal focus.

30. A ray of light is incident on a concave mirror along its principal axis. What will be the angle of reflection?

Ans. Angle of reflection = 0°

31. What will happen to ray of light when it travels from rarer medium to a denser medium?

Ans. Bends towards the normal.

32. What does negative sign in the value of magnification of a mirror indicate?

Ans. Image is real.

33. Name the point inside the lens through which a ray of light goes undeviated?

Ans. Optical centre.

34. Which of the two has a great power? A lens of short focal length or a lens of large focal length?

Ans. Lens of short focal length.

35. Name the lens which always gives an erect and diminished image?

Ans. Concave lens.

36. Which mirror is used as rear view mirror in vehicles and why?

Ans. Convex mirror, wider field of view.

37. Define one dioptre?

Ans. One dioptre is the power of a lens of focal length one meter.

38. The size of an object is 2 cm. The magnification produced by a mirror is +1. What is the size of the image?

Ans. +2cm, because $m = I/O$, $+1 = I/2 \Rightarrow I = +2$

39. When a ray of light passes from a denser medium to a rarer medium which angle is greater: angle of incidence or angle of refraction?

Ans. Angle of refractions.

40. An image formed in a spherical mirror has magnification -2. Is the image real or virtual?

Ans. Real

41. The power of a lens is -2D. Is the lens convex or concave?

Ans. Concave lens.

42. Focal length of a convex mirror is 10 cm. Find the radius of curvature of the mirror?

Ans. 20 cm.

2 Marks Questions

1. A beam of rays, parallel to the principal axis, is incident on a convex mirror. Show diagrammatically, the path of these rays after reflection from the mirror.

Ans.

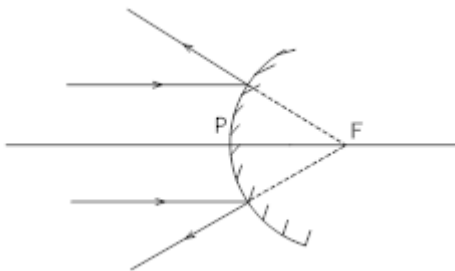

2. Find the power of a concave lens of focal length 2 m?

Ans. $f = 2\text{m}$

$$P = \frac{1}{f}$$

$$P = \frac{1}{2} = 0.5 \text{ Diopetre}$$

3. With respect to air the refractive index of ice is 1.31 and that of rock salt is 1.54. Calculate the refractive index of rock salt with respect to ice?

Ans. $n_{ia} = \frac{n_i}{n_a} = 1.31 \dots \dots (i)$

$$n_{ra} = \frac{n_r}{n_a} = 1.54 \dots \dots (ii)$$

$$nri = \frac{nr}{ni} = \frac{nr}{\frac{na}{ni}}$$

$$nri = \frac{nr}{na} \times \frac{na}{ni} = \frac{1.54}{1.31} = 1.175$$

4. A concave mirror produces three times magnified (enlarged) real image of an object 10 cm in front of it. Where is the image located?

Ans. $m = -3 = \frac{-v}{u}$

$$v = 3u \quad f = ? \quad u = -10\text{cm}$$

$$\frac{1}{f} = \frac{1}{u} + \frac{1}{v}$$

$$v = 3(-10)$$

$$v = -30\text{cm}.$$

5. Three mirrors, one plane, one concave and one convex are lying on the table. How can a person identify them without touching them or using any other apparatus or device?

Ans. Plane mirror produces the image of same size. Concave mirror produced the magnified image while the convex mirror will produce a diminished image.

6. Obtain the formula for the focal length of a lens in terms of object distance (u) and magnification (m)

Ans. $\frac{1}{f} = \frac{1}{v} - \frac{1}{u}$

$$m = \frac{v}{u}$$

$$v = mu$$

$$\frac{1}{f} = \frac{1}{mu} - \frac{1}{u}$$

$$\frac{1}{f} = \frac{1-m}{mu}$$

$$f = \frac{mu}{1-m}$$

7. In what S.I unit is the power of lens stated? A convex lens has a focal length of 50 cm. calculate its power?

Ans. S.I unit of power is Dioptre (D)

$$F=50 \text{ cm}$$

$$P = \frac{1}{f}$$

$$P = \frac{1}{50} \times 100$$

$$P = 2D$$

8. Light enters from air into diamond which has a refractive index of 2.42. Calculate the speed of light in diamond. The speed of light in air is 3.0×10^8 m/s.

Ans. $n = 2.42$

$$v = ?$$

$$c = 3 \times 10^8 \text{ m/s}$$

$$n = \frac{c}{v} \Rightarrow v = \frac{c}{n}$$

$$v = \frac{3 \times 10^8}{2.42}$$

$$v = 1.24 \times 10^8 \text{ m/s}$$

9. Light is incident at an angle of

(i) 30°

(ii) 45° , on the same face of a given rectangular slab. If the angles of refraction, at this face are r_1 and r_2 in the two cases. Obtain the relation between these two angles.

$$\text{Ans. } n = \frac{\sin i}{\sin r} = \frac{\sin 30^\circ}{\sin r_1}$$

$$n = \frac{\sin 45^\circ}{\sin r_2}$$

$$\therefore \sin r_2 = \frac{\sin 45^\circ}{\sin 30^\circ} \sin r_1$$

$$\sin r_2 = \frac{1}{\sqrt{2}} \times (2) \sin r_1$$

$$= \sqrt{2} \sin r_1$$

10. Why do we prefer a convex mirror as a rear view mirror in vehicles?

Ans. Convex mirror is preferred as rearview mirror in vehicles because it always forms virtual erect and diminished image. It also covers the wider field of view.

11. A doctor has prescribed a corrective lens of power 1.5 D. Find the focal length of this lens. Is the prescribed lens diverging or converging.

Ans.
$$F = \frac{1}{\text{Power}}$$

$$F = \frac{1}{1.5\text{m}} = \frac{2}{3}\text{m} = \frac{200}{3}\text{cm}$$

$$f = 66.67\text{cm}$$

Positive sign means it is a converging lens.

12. Define the principle focus of a concave mirror.

Ans. Principal focus of a concave mirror is the point on its principal axis, where light rays coming parallel to principal axis actually converge after reflection from mirror.

13. The radius of curvature of a spherical mirror is 20 cm. what is its focal length?

Ans. Focal length (f) = R/2 = 20 cm/2 = 10 cm.

14. Name a mirror that can give an erect and enlarged image of an object.

Ans. Only a concave mirror can give a erect and enlarged image of an object.

15. Why do we prefer a convex mirror as a rear-view mirror in vehicles?

Ans. We prefer a convex mirror as a rear-view mirror in vehicles because a convex mirror gives an erect and diminished image. As a result, convex mirror help the driver to have much wider field view.

16. Find the focal length of a convex mirror whose radius of curvature is 32 cm.

Ans. Radius of curvature of (R) = 32 cm

Focal length(f) = $R/2 = 32/2 \text{ cm} = 16 \text{ cm}$.

17. A concave mirror produces three times magnified real image of an object placed at 10 cm in front of it. Where is the image located?

Ans. Distance of object from concave mirror (u) = -10 cm.

Magnification (m) = -3

$m = -v/u$

$v = -mu = -(3) \times (-10) = -30 \text{ cm}$.

18. A ray of light traveling in air enters obliquely into water. Does the light ray bend towards or away from the normal? Why?

Ans. The light bends towards the normal on entry into water. It is due to the fact that as compared to air, the water is optically denser medium.

19. Find out, from Table (10.3), the medium having highest optical density. Also, find the medium with lowest optical density.

Ans. As per table, diamond has highest optical density (2.42). Medium with lowest optical density is air (1.0003)

20. You are given kerosene, turpentine and water. In which of these does the light travel fastest? Use the information given in table 10.3

Ans. As the refractive index of water is least out of three substances. Hence speed of light is maximum in water. So, light travels fastest in water.

21. The refractive index of diamond is 2.42. What is the meaning of this statement?

Ans. It means that speed of light in diamond is 2.42 times slower than speed of light in air.

22. Absolute refractive Index of some of material is tabulated below

Material	Rock salt	Kerosene	Water	Diamond
Refractive	1.54	1.44	1.33	2.42

i) In which of these does light travel fastest and why?

ii) arrange these materials in ascending order of their optical densities.

Ans. i) Water due to least refractive index.

ii) Water, Kerosene, Rock salt, diamond

23. A rod of length 10 cm lies along the principal axis of a concave mirror of 10 cm in such a way that the end closer to the pole is 20 cm away from it. Find the length of image?

Ans. $R = 2f = 20$ cm. Thus the nearer end B of the rod AB is at C and hence its image will be formed at B itself

For end A $u = -30$ cm, $f = -10$ cm, $v = -15$ cm Length of image will be at 5 cm

24. Two lenses 1&2 are placed in contact. Focal length of lens 1 is 20 cm and of 2 is – 10 cm. Calculate

i) Total Power of combination

ii) What is the nature of combination.

Ans. (i) $P = -5$ D

(ii) Concave Lens

25. An object is placed 15 cm in front of a lens 'A' and lens gives real, inverted, magnified image and formed at large distance. Lens 'A' is replaced by Lens 'B' and a real, inverted image of the same size as of object is formed.

i) What is the nature of Lens A&B?

ii) What is the focal length of A&B?

Ans. A=Convex lens, B=Convex Lens

An Object is placed and lens gives real, inverted

ii) $F_A = 15\text{cm}, F_B = 7.5\text{cm}$

26. A fish under water is viewing obliquely a fisherman standing on the bank of lake. Does the man look taller or shorter?

Ans. As light travels from rarer to denser medium, it bends towards normal and appears to come from greater height. Therefore, to fish under water man looks taller.

27. What type of lens must be placed at XV so that image I shifts to I'

Ans. concave lens

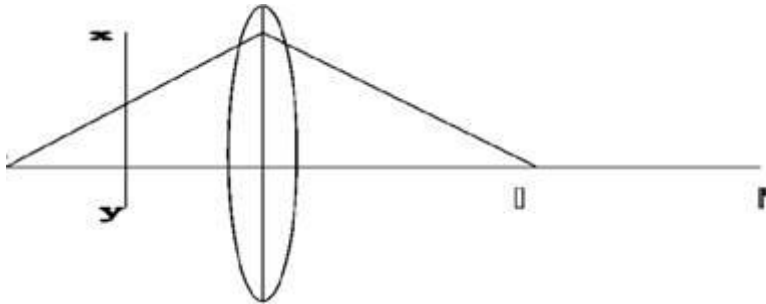

28. Identify the type of lens or mirror placed at XV where O is object and I is image.

Ans. Convex lens (when object is placed between pole and focus)

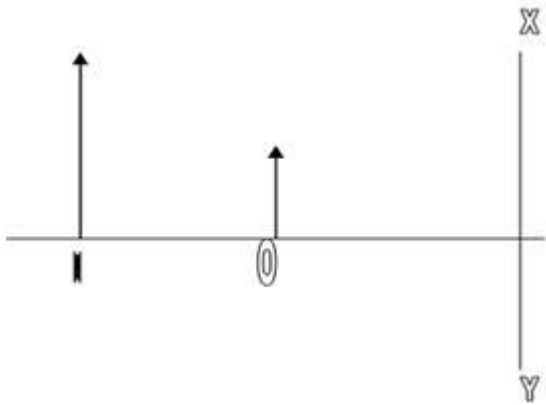

29. An object is placed at a distance of 50 cm from a convex mirror. State two characteristics of the image formed.

Ans. (1) Image is virtual and erect.

(2) Image is diminished.

30. Write two uses of concave mirror.

Ans. (1) Used as reflectors for automobile headlights.

(2) Used as shaving mirror.

31. An object 1 cm high produces a real image 1.5 cm high, when placed at a distance of 15 cm from concave minor. Calculate the position of the image.

Ans. $-v/u=h'/h$, $-v/-15=1.5$

$v = 15 \times 1.5 = -22.5 \text{ cm.}$

32. Find the power of a concave lens of focal length 2m.

Ans. $-p= 1/f$

$=1 = -0.5 \text{ D.}$

33. Which phenomenon occurs when light falls on

(a) highly polished surface

(b) a transparent medium?

Ans. (a) Reflection of light.

(b) Refraction of light.

34. What will happen to a ray of light when it falls normally on a surface?

Ans. No bending of light ray occurs. It means light rays goes straight from one medium to another.

35. What is absolute refractive index?

Ans. When first medium is taken as vaccum, the refractive index of second medium is called as absolute refractive index.

36. If refractive index of glass is 1.65, What is the speed of light in glass?

Ans. Given Refractive index = $n = 1.65$
speed of light in vaccum = $3 \times 10^8 \text{ m s}^{-1}$

Using, Refractive Index = speed of light in vaccum / speed of light in glass

$$1.65 = 3 \times 10^8 \text{ ms}^{-1} / \text{speed of light in glass}$$

$$\text{speed of light in glass} = 3 \times 10^8 / 1.65$$

$$= 1.8 \times 10^8 \text{ m s}^{-1}$$

Therefore, speed of light in glass is $1.8 \times 10^8 \text{ ms}^{-1}$

37. The magnification "m" for a mirror is +1 what does this signif.

Ans. (a) Image is of same size as the object.

(b) Image is virtual and erect.

3 Marks Questions

1. An object is placed at a distance of 12 cm in front of a concave mirror. It forms a real image four times larger than the object. Calculate the distance of the image from the mirror

Ans. $u = -12 \text{ cm}$

$$m = -4$$

$$v = ?$$

$$\frac{-v}{u} = -4$$

$$v = 44$$

$$v = 4(-12)$$

$$v = -48 \text{ cm}$$

2. Draw a ray diagram to represent the nature, position and size of the image formed by a convex lens for the object placed at

(a) infinity

(b) Between F_1 and optical centre (O) (0)

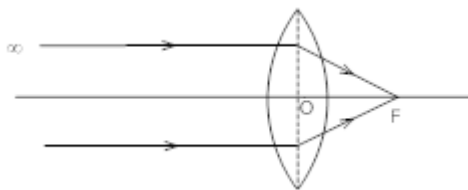

Ans. (a) Size – Point sized

Position – At focus

Nature – Real & Inverted

(b) Size – highly magnified

Position – same side of the lens where the object is placed

Nature – virtual & erect.

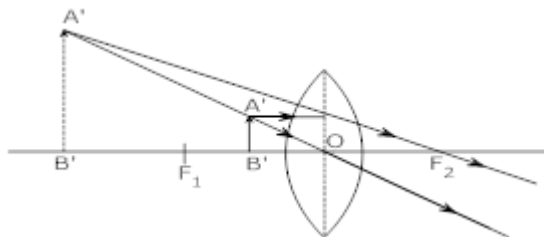

3. A convex mirror used on a bus has a focal length of 200 cm. If a scooter is located at 100 cm from this mirror find the position, nature and magnification of the image formed in the mirror.

Ans. $f = +200\text{cm}$

$$U = -100\text{cm}$$

$$\frac{1}{f} = \frac{1}{v} + \frac{1}{V}$$

$$\frac{1}{v} = \frac{1}{f} - \frac{1}{V}$$

$$\frac{1}{v} = \frac{1}{200} + \frac{1}{100}$$

$$\frac{1}{v} = \frac{3}{200}$$

$$v = \frac{200}{3} = 66.67\text{cm}$$

$$m = \frac{-v}{V} = \frac{-66.67}{-100}$$

$$m = 0.666$$

Image is virtual.

4. A concave lens has focal length of 20 cm. At what distance from the lens a 5 cm tall object be placed so that it forms an image at 15 cm from the lens? Also calculate the size of the image formed?

Ans. $f = 20\text{cm}$

$$H = 5\text{ cm}$$

$$V = -15\text{ cm}$$

$$h' = -?$$

$$U = ?$$

$$\frac{1}{u} = \frac{-1}{15} + \frac{1}{20}$$

$$\frac{1}{u} = \frac{-4+3}{60} = \frac{-1}{60}$$

$$U = -60\text{ cm}$$

$$\frac{h'}{h} = \frac{v}{u}$$

$$\frac{h'}{5} = \frac{-15}{-60}$$

$$h' = \frac{15 \times 5}{60}$$

$$h' = \frac{5}{4} = 1.25\text{cm}$$

5. An object is kept at a distance of 15 cm from a

(a) convex mirror

(b) concave lens

(c) Plane mirror.

The focal length of the convex mirror and the concave lens are 10 cm each. Draw the appropriate ray diagrams, showing the formation of image, in each of the three cases.

Ans. Here $U=15$ cm $f=10$ cm for convex & concave

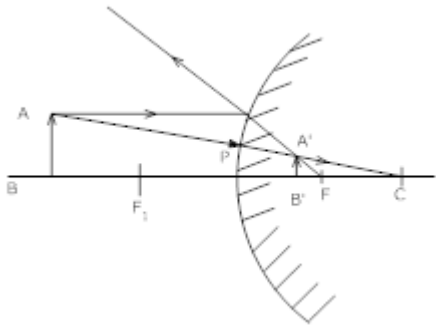

(a) Between Pole and focus virtual & erect Diminished

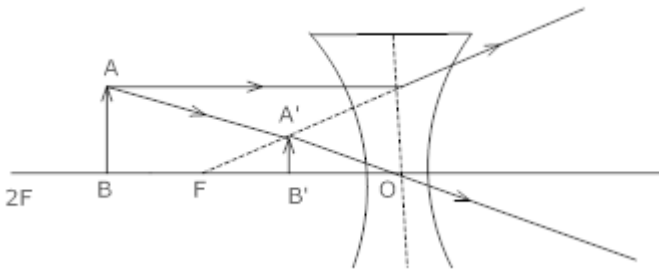

(b) Between optical centre & focus diminished, virtual & erect

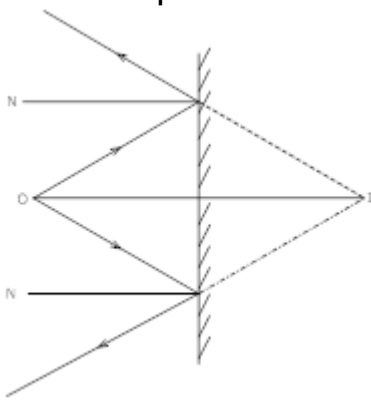

(c)

6. State the mirror formula for determining the focal length of spherical mirrors write the meanings of the symbols used An object is placed at a distance of 25 cm. from a concave mirror of focal length 15 cm. Calculate the distance of the image from the mirror.

Ans.
$$\frac{1}{f} = \frac{1}{u} + \frac{1}{v}$$

Where f is the focal length of the mirror

U is the object distance

V is the Image distance

$U=-25$ cm

$F=-15$ cm

$V=?$

$$\frac{1}{f} = \frac{1}{v} + \frac{1}{u}$$

$$\frac{1}{-15} = \frac{1}{v} + \frac{1}{-25}$$

$$\frac{1}{v} = \frac{-1}{15} + \frac{1}{25}$$

$$\frac{1}{v} = \frac{-1}{15} + \frac{1}{25}$$

$$\frac{1}{v} = \frac{-5+3}{75}$$

$$\frac{1}{v} = \frac{-2}{75}$$

$$v = \frac{-75}{2} = -37.5 \text{ cm}$$

7. Find the position, nature and size of the image formed by a convex lens of focal length 12 cm of an object 5 cm high placed at a distance 20 cm from it.

Ans. $F = 12 \text{ cm}$

$$h = 5 \text{ cm}$$

$$V = -20 \text{ cm}$$

$$\frac{1}{f} = \frac{1}{v} - \frac{1}{u}$$

$$\frac{1}{12} = -\left(\frac{1}{-20}\right) + \frac{1}{v}$$

$$\frac{1}{v} = \frac{1}{20} - \frac{1}{12}$$

$$\frac{1}{v} = -\frac{12+20}{240} = \frac{08}{240}$$

$$v = \frac{240}{8} = 30 \text{ cm}$$

$$m = \frac{v}{u} = \frac{30}{-20} = -1.5$$

m is negative so the image is real and inverted

$$\frac{h_1}{h} = \frac{v}{u}$$

$$\frac{h_1}{5} = -1.5$$

$$h_1 = -1.5 \times 5$$

$$h_1 = -7.5 \text{ cm}$$

8. An object is kept at a distance of

(a) $\frac{a}{2}$ (b) $\left(\frac{3}{2}\right)a$ from a convex lens having focal length of magnitude (a) Draw ray diagrams showing the formation of images formed in the two cases.

Ans. (a) for $u = \frac{a}{2}$ $f = a$

Position of the object – Between O & F

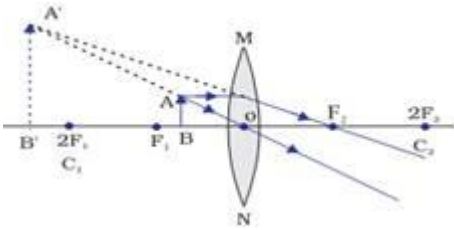

(b) $u = \left(\frac{3}{2}\right)a$ $f = a$ For

Position of the object – Between F and 2F

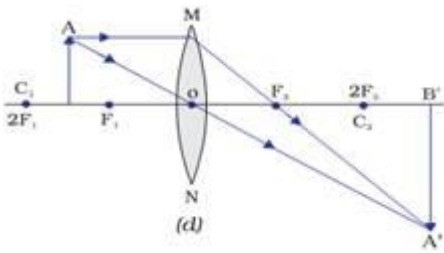

9. A concave mirror is used to form an erect and enlarged image of a given object. Where is the image located with respect to the mirror? Draw the corresponding ray diagram.

Ans.

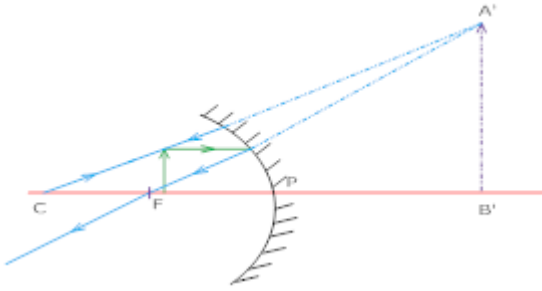
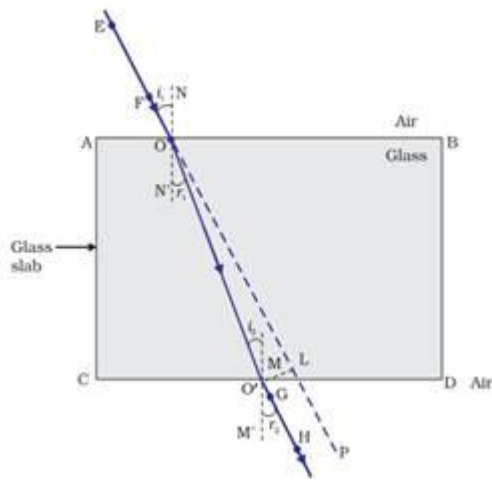

Image is located behind the mirror. It is highly magnified and virtual and erect.

10. How can you show that if a ray enters a rectangular glass slab obliquely and emerges from the opposite face, the emergent ray is parallel to the incident ray?

Ans. $\angle r_1 = \angle r_2$ (Alternate

angles)



$$n_{21} = \frac{\sin i}{\sin r_1} \dots\dots(1)$$

At face AB

$$n_{21} = \frac{\sin e}{\sin r_2}$$

At face CD

$$\Rightarrow n_{12} = \frac{\sin r_2}{\sin e} \dots\dots(2)$$

From (1) & (2)

$$\frac{\sin i}{\sin r_1} = \frac{\sin e}{\sin r_2}$$

$$\Rightarrow i = e \quad (\because \angle r_1 = \angle r_2)$$

11. Light enters from air to glass having refractive index 1.50. What is the speed of light in glass? The speed of light in vacuum is $3 \times 10^8 \text{ m/s}$.

Ans. Speed of light in vacuum (c) = $3 \times 10^8 \text{ m/s}$.

Refractive index = c/v .

Speed of light in glass = $3 \times 10^8 \text{ m/s} / 1.50$

= $2 \times 10^8 \text{ m/s}$

12. We wish to obtain an erect image of an object, using a concave mirror of focal length 15 cm.

What should be the range of distance of the object from mirror? What is the nature of image? Is the image larger or smaller than the object? Draw a ray diagram to show the image formation in this case.

Ans. Object must be placed in front of concave mirror between its pole and principal focus at a distance less than 15 cm. The image formed will be virtual and erect. The size of the image is larger than the object. The ray diagram is as follows:

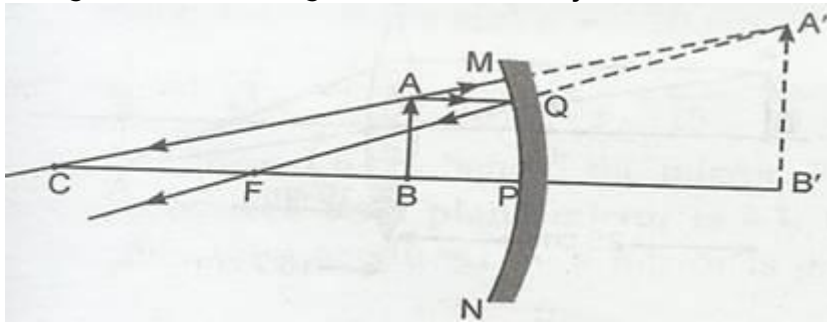

13. Name the type of mirror used in the following situations:

- (a) Headlights of a car
- (b) Side/rear-view mirror of a vehicle.
- (c) Solar furnace.

Support your answer with reason.

Ans. (a) Headlights of a car- concave mirror to give parallel beam of light after reflection from concave mirror.

(b) Side/rear-view mirror of vehicle- convex mirror as it forms virtual erect and diminished image to give wider view field.

(c) Solar furnace- concave mirror to concentrate sunlight to produce heat in solar furnace.

14. An object is placed at a distance of 10 cm from a convex mirror of focal length 15 cm. Find the position and nature of image.

Ans. $f = +15 \text{ cm}$, $u = -10 \text{ cm}$.

$$1/f = 1/v + 1/u$$

$$1/v = 1/15 + 1/10$$

$$1/v = 5/30$$

$$v = +30 \text{ cm}.$$

The image is formed 6 cm behind the mirror, it is a virtual and erect image.

15. The magnification produced by a plane mirror is +1. What does this means?

Ans. $m = h_i / h_o = v / u$

Magnification produced by a plane mirror is +1 which means that size of image formed is exactly equal to size of object behind the mirror.

16. An object 5.0 cm in length is placed at a distance of 20 cm in front of a convex mirror of radius of curvature 30 cm. Find the position of the image, its nature and size.

Ans. Radius of curvature (R) = 30 cm

$$f = R/2 = 30/2 = 15 \text{ cm}$$

$$u = -20 \text{ cm}, h = 5 \text{ cm}.$$

$$1/v + 1/u = 1/f$$

$$1/v = 1/15 + 1/20 = 7/60$$

$$v = 60/7 = 8.6 \text{ cm}.$$

image is virtual and erect and formed behind the mirror.

$$h_i / h_o = v / u$$

$$h_i / 5 = 8.6 / 20$$

$$h_i = 2.2 \text{ cm}.$$

Size of image is 2.2 cm.

17. An object of size 7.0 cm is placed at 27 cm in front of a concave mirror of focal length 18 cm. At what distance from the mirror should a screen be placed, so that a sharp focused image can be obtained? Find the size and the nature of the image.

Ans. $u = -27 \text{ cm}$, $f = -18 \text{ cm}$. $h_o = 7.0 \text{ cm}$

$$1/v = 1/f - 1/u$$

$$1/v = -1/18 + 1/27 = -1/54$$

$$V = -54 \text{ cm.}$$

Screen must be placed at a distance of 54 cm from the mirror in front of it.

$$h_i / h_o = v / u$$

$$h_i / 7 = +54 / -27$$

$$h_i = -2 \times 7 = -14 \text{ cm.}$$

Thus, the image is of 14 cm length and is inverted image.

18. Find the focal length of a lens of power -2.0 D. What type of lens is this?

Ans. Power of lens (P) = -2.0 D

$$P = 1/f \text{ or } f = 1/P$$

$$f = 1/-2.0 = -0.5 \text{ m.}$$

(-ve) sign of focal length means that the lens is concave lens.

19. A doctor has prescribed a corrective lens of power +1.5 D. Find the focal length of the lens. Is the prescribed lens diverging or converging?

Ans. P = +1.5 D

$$f = 1/P = 1/+1.5 = 0.67 \text{ m.}$$

As the power of lens is (+ve), the lens is converging lens.

20. You are given three lenses.

i) a concave lens of focal length 25 cm.

ii) a convex lens of focal length $\frac{1}{4}$ m and

iii) a convex lens of focal length 100 cm.

Which combination out of these three lenses will form a lens of zero power?

Ans. Combination of concave lens of focal length of 25 cm and a convex lens of focal length of $\frac{1}{4}$ m

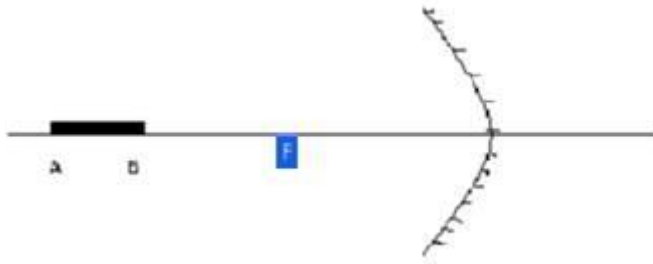

21. A rod of length 10 cm lies along the principal axis of a concave mirror of 10 cm in such a way that the end closer to the pole is 20 cm away from it. Find the length of image?

Ans. $R = 2f = 20$ cm. Thus the nearer end B of the rod AB is at C and hence its image will be formed at B itself For end A $u = -30$ cm, $f = -10$ cm, $v = -15$ cm Length of image will be at 5 cm

5 Marks Questions

1. A convex lens has a focal length of 10 cm. At what distance from the lens should the object be placed so that it forms a real and inverted image 20 cm. away from the lens? What would be the size of the image formed if the object is 2 cm high? With the help of a ray diagram show the formation of the image by the lens in this case?

Ans. $f = +10\text{cm}$

$$v = +20\text{cm}$$

$$\frac{1}{f} = \frac{1}{v} + \frac{1}{V}$$

$$\frac{1}{10} = \frac{1}{20} + \frac{1}{V}$$

$$\frac{1}{V} = \frac{1}{20} - \frac{1}{10}$$

$$\frac{1}{V} = \frac{1-2}{20}$$

$$\frac{1}{V} = \frac{-1}{20}$$

$$V = -20\text{cm}$$

$$m = \frac{-v}{V} = \frac{-20}{-20}$$

$$m = +1$$

image formed is real.

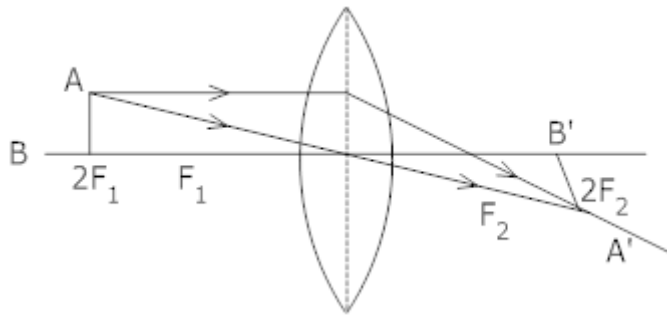

Object at $2F_1$

image formed at $2F_2$

Same size & Real & inverted

2. Draw a ray diagram to show the use of a convex lens for the formation of images having the following characteristics.

(a) Real & inverted and diminished

(b) Virtual, erect & magnified.

Ans. (a) Image is formed between F_2 & $2F_2$, Diminished real and inverted.

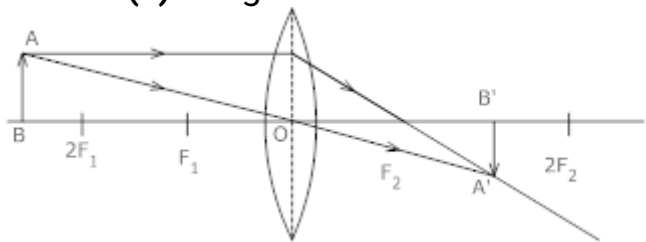

(b) Virtual & erect, highly magnified, same side of the lens where the object is placed.

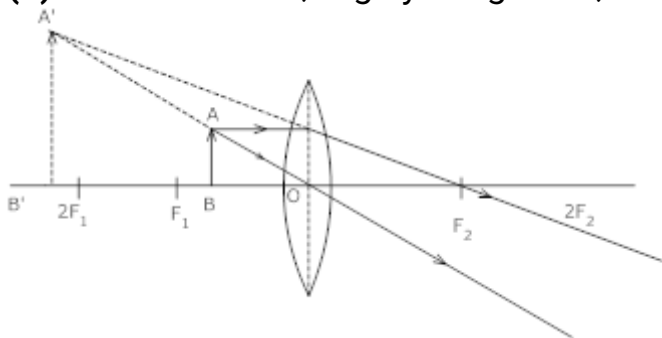

3. A convex lens forms a real and inverted image of a needle at distance of 50 cm. from it. Where is the needle placed in front of the convex lens if the image is equal to the size of objects? Also, find the power of lens.

Ans. Image distance (v) = +50 cm, $h_i = h_o$

$$h_i/h_o = v/u$$

$$u = v \times h_o / h_i$$

$$= 50 \times h_o / h_i$$

$$= 50 \text{ cm.}$$

Now,

$$u = -50 \text{ cm}$$

$$v = + 50 \text{ cm.}$$

$$f = ?$$

$$1/f = 1/v - 1/u$$

$$1/f = 1/50 + 1/50$$

$$f = + 25 \text{ cm.} = 0.25 \text{ m}$$

$$\text{Power of lens (P)} = 1/f$$

$$= 1/ 0.25 = + 4\text{D.}$$

4. One-half of a convex lens is covered with a black paper. Will this lens produce a complete image of the object? Verify your answers experimentally. Explain your observations.

Ans. When one-half of a convex lens is covered with a black paper, this lens produces a complete image of the object. To prove it we perform experiment:

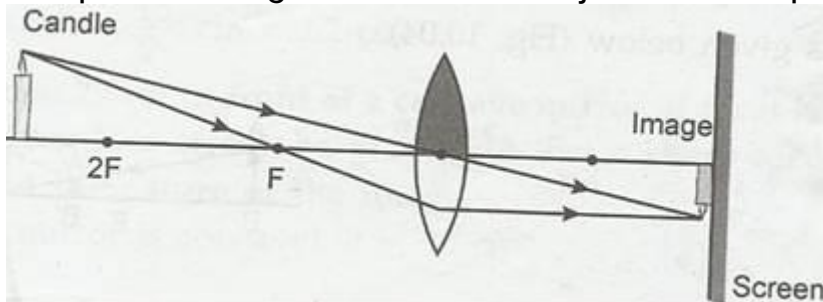

Take a concave mirror and cover half part of its by using black paper. Place it vertically in a stand. On one side of it place a burning candle. On opposite side of the lens fix a white screen. Adjust the position of candle or screen till clear image of burning candle is formed on the screen. We observe that the image is complete image of the object.

From the experimental observations, we find that image formation does not depend upon the size of a lens. A similar lens can also form complete image of an object placed in front of it. However, brightness of the image decreases when some part of lens is blocked. It is because now lesser number of rays pass through the lens.

5. An object 5 cm in length is held 25 cm away from a converging lens of focal length 10 cm. Draw the ray diagram and find the position, size and the nature of the image formed.

Ans.

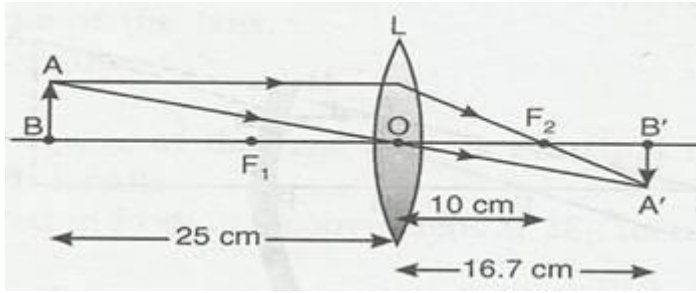

$f = +10 \text{ cm}$, $u = -25 \text{ cm}$ and $h_o = 5 \text{ cm}$

$$\frac{1}{f} = \frac{1}{v} - \frac{1}{u}$$

$$\frac{1}{v} = \frac{1}{10} - \frac{1}{15}$$

$$\frac{1}{v} = \frac{3}{50}$$

$$v = \frac{50}{3} \text{ cm.}$$

The image is real and inverted at a distance of 16.7 cm from the lens on opposite side.

$$\text{Magnification (m)} = \frac{h_i}{h_o} = \frac{v}{u}$$

$$\frac{h_i}{5} = \frac{16.7}{-25}$$

$$h_i = -\frac{10}{3} \text{ cm. image is inverted and diminished.}$$

6. A convex lens of focal length 15 cm forms an image 10 cm from the lens. How far is the object placed from the lens? Draw the ray diagram.

Ans. $f = -15 \text{ cm}$, $v = -10 \text{ cm}$

$$\frac{1}{v} - \frac{1}{u} = \frac{1}{f}$$

$$\frac{1}{u} = \frac{1}{15} - \frac{1}{10} = -\frac{1}{30}$$

$$u = -30 \text{ cm.}$$

Ray diagram as follows:

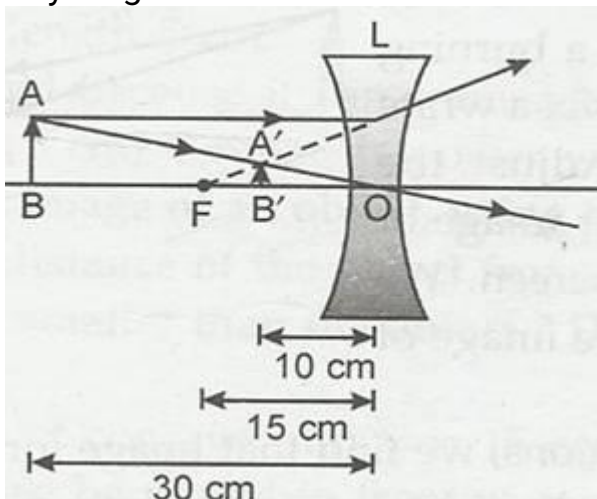

HOTS

1 Marks Questions

1. **How does image changes when the face is slowly moved away from inner face of a shining spoon?**
Ans. As the face is moved away than after a particular time image becomes inverted.
2. **Due to which property of light, sharp shadow of an object is obtained?**
Ans. straight line property of the light.
3. **Identify the type of lens or mirror placed at XY where O is object and I is image.**

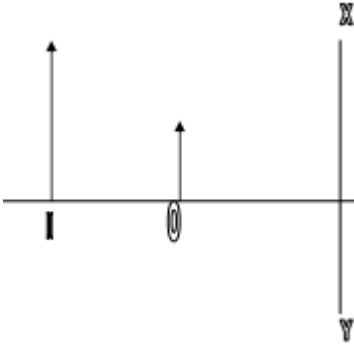

Ans. Convex lens (when object is placed between pole and focus)

4. **What type of lens must be placed at XY so that image I shifts to I'**

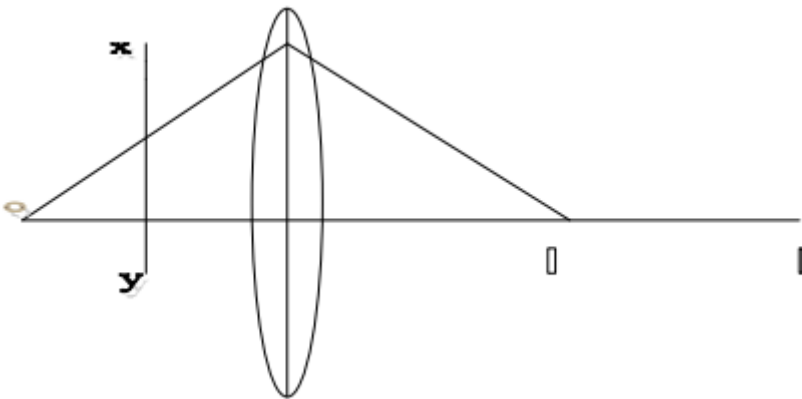

Ans. concave lens

5. **A ray AFB is incident on a spherical mirror whose centre of curvature is 2 F. In which direction will it reflect?**
Ans. It will reflect towards the object side parallel to principal axis.
6. **A ray of light is incident at angle of 35° to a plane surface. What will the angle of reflection?**
Ans. 55°
7. **A fish under water is viewing obliquely a fisherman standing on the bank of lake. Does the man look taller or shorter?**
Ans. As light travels from rarer to denser medium, it bends towards normal and appears to come from greater height. Therefore to fish under water man looks taller.

Two marks Questions

1. **An Object is placed 15 cm in front of a lens 'A' and lens gives real, inverted , magnified image and formed at large distance. Lens 'A' is replaced by Lens 'B' and a real, inverted image of the same size as of object is formed.**
 - i. **What is the nature of Lens A&B?**
 - ii. **What is the focal length of A&B?**

Ans.

- i. A=Convex lens, B=Convex Lens
 - ii. $f_A=15\text{cm}$, $f_B=7.5\text{cm}$
2. **Two lenses 1 & 2 are placed in contact. Focal length of lens 1 is 20 cm and of 2 is -10cm. Calculate**
- i. **Total Power of combination**
 - ii. **What is the nature of combination.**

Ans. (i) $P = -5\text{ D}$ (ii) Concave Lens

3. **For the same angle of incidence the angle of refraction in three different media A, B and C are 30° , 45° and 60° respectively. In which medium will the velocity of light be minimum?**

Ans.

- i. $\mu_A = \sin i / \sin 30$, $\mu_B = \sin i / \sin 45$, $\mu_C = \sin i / \sin 60$
 $\mu_A > \mu_B > \mu_C$, $\mu = c/v$ as $\mu_A = \text{max}$, $v_A = \text{min}$.
4. **You are given three lenses.**
- i. a concave lens of focal length 25 cm.
 - ii. a convex lens of focal length $\frac{1}{4}\text{ m}$ and
 - iii. a convex lens of focal length 100 cm.
- Which combination out of these three lenses will form a lens of zero power?

Ans. Combination of concave lens of focal length of 25 cm and a convex lens of focal length of $\frac{1}{4}\text{m}$

Three Marks Questions

1. **A rod of length 10 cm lies along the principal axis of a concave mirror of $f = 10\text{ cm}$ in such a way that the end closer to the pole is 20cm away from it. Find the length of image?**

Ans. $R = 2f = 20\text{cm}$. Thus the nearer end B of the rod AB is at C and hence its image will be formed at B itself

For end A $u = -30\text{ cm}$, $f = -10\text{ cm}$, $v = -15\text{ cm}$

Length of image will be at 5 cm

2. **Absolute refractive Index of some of material is tabulated below**

Material	Rock salt	Kerosene	Water	Diamond
Refractive index	1.54	1.44	1.33	2.42

- i. **In which of these does light travel fastest and why?**
- ii. **arrange these materials in ascending order of their optical densities.**

Ans.

- i. Water due to least refractive index.
 - ii. Water, Kerosene, Rock salt, diamond
3. **A object is placed on the axis of a convex lens. Draw the neat ray diagrams for formation of image when**

- i. Object is placed at a distance more than double of its focal length.
- ii. The object is at a distance equal to double of its focal length and
- iii. The object is at a distance more than focal length but less than double of its focal length.

Ans.

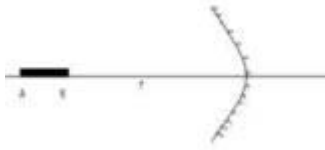

1. **Where is the image formed in a convex mirror, when the object is anywhere in front of it?**
Ans. Between pole and focus, behind the convex mirror.
2. **A person uses concave mirror for shaving, where should he position his face in front of it?**
Ans. Between pole and principal focus.
3. **A ray of light is incident on a concave mirror along its principal axis, What will be the angle of reflection?**
Ans. Angle of reflection = 0
4. **What will happen to ray of light when it travels from rarer medium to a denser medium?**
Ans. Bends towards the normal
5. **What does negative sign in the value of magnification of a mirror indicate?**
Ans. Image is real
6. **Name the point inside the lens through which a ray of light goes undeviated?**
Ans. Optical centre
7. **Which of the two has a great power? A lens of short focal length or a lens of large focal length?**
Ans. Lens of short focal length.
8. **Name the lens which always gives an erect and diminished image?**
Ans. Concave lens
9. **Which mirror is used as rear view mirror in vehicles and why?**
Ans. Convex mirror, wider field of view.
10. **Define one diopter?**
Ans. One diopter is the power of a lens of focal length one meter.
11. **The size of an object is 2cm The magnification produced by a mirror is +1. What is the size of the image?**
Ans. +2cm, because $m = I/O$, $+1 = 1/2 = +2$
12. **When a ray of light passes from a denser medium to a rarer medium which angle is greater: angle of incidence or angle of refraction?**
Ans. Angle of refractions.
13. **An image formed in a spherical mirror has magnification -2. Is the image real or virtual?**
Ans. Real.
14. **The power of a lens is -2D. Is the lens convex or concave?**
Ans. Concave lens.

15. **Focal length of a convex mirror is 10cm Find the radius of curvature of the mirror?**

Ans. 20cm.

16. **An object is placed at a distance of 50cm from a convex mirror. State two characteristics of the image formed.**

Ans.

1. Image is virtual and erect.
2. Image is diminished.

17. **Write two uses of concave mirror.**

Ans. (1) Used as reflectors for automobile headlights.

18. **An object 1cm high produces a real image 1.5cm high, when placed at a distance of 15cm from concave mirror. Calculate the position of the image.**

Ans. $-v/u = h'/h$, $-v/-15 = -1.5/1$

$v = 15 \times 1.5 = -22.5\text{cm}.$

19. **Find the power of a concave lens of focal length 2m.**

Ans. $P = 1/f = 1/-2 = -0.5\text{D}.$

20. **Which phenomenon occurs when light falls on**

- a. highly polished surface
- b. a transparent medium?

Ans.

- a. Reflection of light.
- b. Refraction of light.

21. **What will happen to a ray of light when it falls normally on a surface?**

Ans. No bending of light ray occurs. It means light rays goes straight from one medium to another.

22. **What is absolute refractive index?**

Ans. When first medium is taken as vacuum, the refractive index of second medium is called as absolute refractive index.

23. **If refractive index of glass is 1.65, What is the speed of light in glass?**

Ans. Refractive Index of glass

$$= \frac{\text{Speed of Light in vacuum}}{\text{Speed of Light in glass}} \rightarrow 1.65 = \frac{3 \times 10^8}{V_g}$$

$$\rightarrow V_g = \frac{3 \times 10^8}{1.65} \rightarrow 1.8 \times 10^8 \text{ m/s}$$

24. **The magnification "m" for a mirror is +1 What does this signify?**

Ans.

- a. Image is of same size as the object.
- b. Image is virtual and erect.

